

SUZUKI

OWNER'S MANUAL

GS1100E

ACCESSORY INSTALLATION AND PRECAUTION SAFETY TIPS

There are a great variety of accessories available to Suzuki owners. Suzuki can not have direct control over the quality or suitability of accessories you may wish to purchase. The addition of unsuitable accessories can lead to unsafe operating conditions. It is not possible for Suzuki to test each accessory on the market or combinations of all the available accessories; however, your dealer can assist you in selecting quality accessories and installing them correctly.

Use extreme caution when selecting and installing the accessories for your Suzuki. We have developed some general guidelines which will aid you when deciding whether, and how to equip your motorcycle.

- (1) Never exceed the GVWR (Gross Vehicle Weight Rating) shown on the Safety Label attached to the steering stem frame tube. The GVWR is the combined weight of the machine, accessories, payload, rider and passenger. When selecting your accessories, keep in mind the weight of the rider and passenger as well as the weight of the accessories. The additional weight of the accessories may not only create an unsafe riding condition but may also affect the steering ease.

GVWR – GS1100E : 467 kg (1030 lbs)

- (2) Anytime that additional weight or aerodynamic affecting accessories are installed, they should be mounted as low as possible, as close to the motorcycle and as near the center of gravity as is feasible. The mounting brackets and other attachment hardware should be carefully checked to ensure that it provides for a rigid, non-moveable mount. Weak mounts can allow the shifting of the weight and create a dangerous, unstable condition.
- (3) Inspect for proper ground clearance and bank angle. An improperly mounted load could critically reduce these two safety factors. Also determine that the "load" does not interfere with the operation of the suspension, steering or other control operations.

TABLE OF CONTENTS

	Page
Consumer Information	4
Accessory Installation and Precaution Safety Tips	4
Vehicle Stopping Distance.	6
Acceleration and Passing Ability.	7
Safe Riding Recommendation For Motorcycle Riders.	8
Serial Number Location	10
Location of Parts.	11
Controls	12
Fuel and Oil Recommendation.	22
Break-In	23
Inspection Before Riding	24
Riding Tips	25
Emission Information.	28
Periodic Maintenance Schedule	29
Inspection and Maintenance	31
Troubleshooting	61
Storage Procedures	62
Specifications	64
Wiring Diagram	66

ACCESSORY INSTALLATION AND PRECAUTION SAFETY TIPS

There are a great variety of accessories available to Suzuki owners. Suzuki can not have direct control over the quality or suitability of accessories you may wish to purchase. The addition of unsuitable accessories can lead to unsafe operating conditions. It is not possible for Suzuki to test each accessory on the market or combinations of all the available accessories; however, your dealer can assist you in selecting quality accessories and installing them correctly.

Use extreme caution when selecting and installing the accessories for your Suzuki. We have developed some general guidelines which will aid you when deciding whether, and how to equip your motorcycle.

- (1) Never exceed the GVWR (Gross Vehicle Weight Rating) shown on the Safety Label attached to the steering stem frame tube. The GVWR is the combined weight of the machine, accessories, payload, rider and passenger. When selecting your accessories, keep in mind the weight of the rider and passenger as well as the weight of the accessories. The additional weight of the accessories may not only create an unsafe riding condition but may also affect the steering ease.

GVWR – GS1100E : 467 kg (1030 lbs)

- (2) Anytime that additional weight or aerodynamic affecting accessories are installed, they should be mounted as low as possible, as close to the motorcycle and as near the center of gravity as is feasible. The mounting brackets and other attachment hardware should be carefully checked to ensure that it provides for a rigid, non-moveable mount. Weak mounts can allow the shifting of the weight and create a dangerous, unstable condition.
- (3) Inspect for proper ground clearance and bank angle. An improperly mounted load could critically reduce these two safety factors. Also determine that the "load" does not interfere with the operation of the suspension, steering or other control operations.

- (4) Accessories fitted to the handlebars or the front fork area can create serious stability problems. This extra weight will cause the motorcycle to be less responsive to your steering control. The weight may also cause oscillations in the front end and lead to instability problems. Accessories added to the handlebar or front fork of the machine should be as light as possible and kept to a minimum.
- (5) Windshields, fairings, backrests, saddlebags, travel trunks, etc., may affect the stability of the motorcycle due to their aerodynamic effects. The motorcycle may be affected by a lifting condition or by an instability in cross winds or when being passed or passing large vehicles. Improperly mounted or poorly designed accessories can result in an unsafe riding condition, therefore, caution should be used when selecting and installing all accessories.
- (6) Certain accessories displace the rider from his normal riding position. This limits the freedom of movement of the rider and may limit his control ability.
- (7) Additional electrical accessories may overload the existing electrical system. Severe overloads may damage the wiring harness or create a dangerous situation due to the loss of electrical power during the operation of the motorcycle.

When carrying a load on the motorcycle, mount it as low as possible and as close as possible to the machine. An improperly mounted load can create a high center of gravity which is very dangerous and makes the motorcycle difficult to handle. The size of the "load" can also affect the aerodynamics and handling of the motorcycle. Balance the load between the left and right side of the motorcycle and fasten it securely.

VEHICLE STOPPING DISTANCE

This figure indicates braking performance that can be met or exceeded by the vehicle to which it applies, without locking the wheels, under different condition of loading and with partial failures of the braking system.

NOTICE: The information presented represents results obtainable by skilled drive under controlled road and vehicle conditions, and the information may not be correct under other conditions.

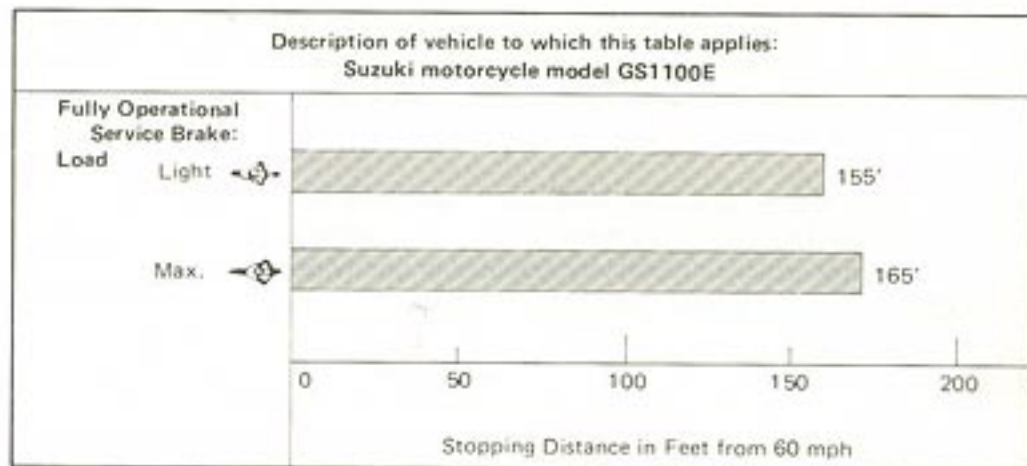

ACCELERATION AND PASSING ABILITY

The figure indicates passing times and distances that can be met or exceeded by the vehicle to which it applies, in the situations diagrammed.

The low-speed pass assumes an initial speed of 20 mph and a limiting speed of 35 mph. The high-speed pass assumes an initial speed of 50 mph and a limiting speed of 80 mph.

NOTICE: The information presented represents results obtainable by skilled driver under controlled road and vehicle conditions, and the information may not be correct under other conditions.

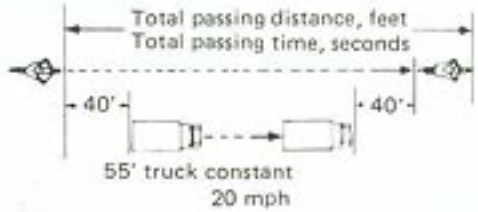
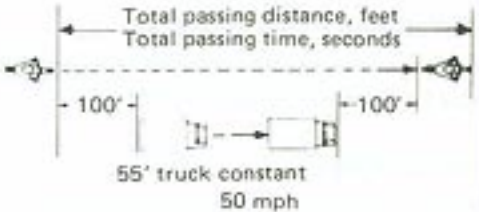
Description of vehicle to which this table applies: Suzuki motorcycle model GS1100E	Summary Table Low-speed pass 343 feet, 6.9 seconds High-speed pass 823 feet, 7.7 seconds
<p>Low-speed: Initial speed: 20mph Limiting speed: 35 mph</p>  <p>40' 40'</p> <p>55' truck constant 20 mph</p>	<p>High-speed: Initial speed: 50 mph Limiting speed: 80 mph</p>  <p>100' 100'</p> <p>55' truck constant 50 mph</p>

SAFE-RIDING RECOMMENDATION FOR MOTORCYCLE RIDERS

Motorcycle riding is great fun and an exciting sport. Motorcycle riding also requires that some extra precautions be taken to ensure the safety of the rider and passenger. These precautions are:

WEAR A HELMET

Motorcycle safety equipment starts with a quality safety helmet.

One of the most serious injuries that can happen is a head injury. ALWAYS wear a properly approved helmet. You should also wear suitable eye protection.

RIDING APPAREL

Loose fancy clothing can be uncomfortable and unsafe when riding your motorcycle. Choose good quality motorcycle riding apparel when riding your motorcycle.

INSPECTION BEFORE RIDING

Review thoroughly the instructions in the "INSPECTION BEFORE RIDING" section of this manual. Do not forget to perform an entire safety inspection to ensure the safety of the rider and its passenger.

FAMILIARIZE YOURSELF WITH THE MOTORCYCLE

Your riding skill and your mechanical knowledge form the foundation for safe riding practices. We suggest that you practice riding your motorcycle in a non-traffic situation until you are thoroughly familiar with your machine and its controls. Remember practice makes perfect.

KNOW YOUR LIMITS

Ride within the boundaries of your own skill at all times. Knowing these limits and staying within them will help you to avoid accidents.

BE EXTRA SAFETY CONSCIOUS ON BAD WEATHER DAYS

Riding on bad weather days, especially wet ones, requires extra caution. Braking distances double on a rainy day. Stay off of the painted surface marks, manhole covers and greasy appearing areas as they can be especially slippery. Use extreme caution at railway crossings and on metal gratings and bridges. Whenever in doubt about road conditions, slow down!

MOTORCYCLE SAFETY FOUNDATIONS "RIDING TIPS FOR THE MOTORCYCLIST" HANDBOOK

This special manual, supplied in the pouch with your Owner's Manual, contains safety tips on a wide variety of topics. This manual can increase your riding enjoyment and safety and should be read thoroughly.

SERIAL NUMBER LOCATION

The frame and/or engine serial numbers are used to register the motorcycle. They are also used to assist your dealer when ordering parts or referring to special service information;

The frame number is stamped on the steering head tube and steering head I.D. plate. The engine serial number is stamped on the left side of the crankcase assembly.



Frame number



Engine number

LOCATION OF PARTS

- | | |
|--------------------------------|--------------------------|
| ① Engine oil inspection window | ⑨ Ignition switch |
| ② Center stand | ⑩ Front brake lever |
| ③ Rear brake pedal | ⑪ Throttle grip |
| ④ Passenger hand rail | ⑫ Speedometer |
| ⑤ Fuelcock | ⑬ Clutch lever |
| ⑥ Gearshift lever | ⑭ Left handlebar switch |
| ⑦ Side stand | ⑮ Right handlebar switch |
| ⑧ Tachometer | ⑯ Carburetor choke knob |

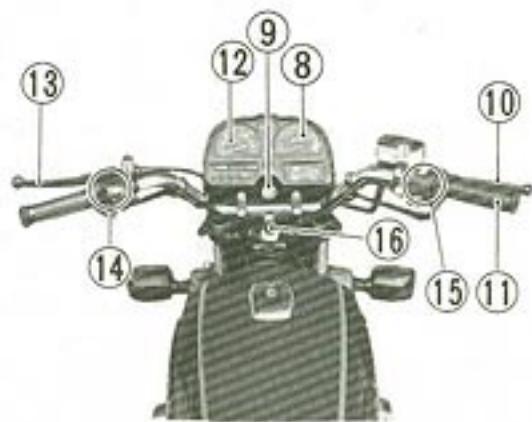
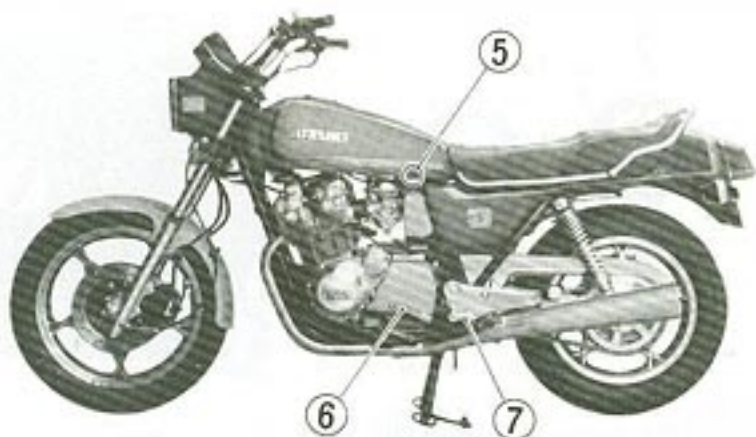

CONTROLS

KEY



The GS1100E comes equipped with two (2) identical keys. Keep the spare key in a safe place.

IGNITION SWITCH



The ignition switch has four (4) positions:

"OFF" POSITION

All electrical circuits are cut off.

"ON" POSITION

The ignition circuit is completed and the engine can now be started. The headlight and taillight will automatically be turned on when the key is in this position. The key cannot be removed from the ignition switch in this position.

"PARKING" POSITION ("P" POSITION)

When parking the motorcycle, turn the handlebar all the way to the right or to

the left. Push down and turn the key to the parking position. The key can now be removed and the taillight will remain lit and the steering will be locked. This position is for night time roadside parking to increase visibility.

"LOCK" POSITION

To lock the steering, turn the handlebar all the way to the right or the left. Push down and turn the key to the "LOCK" position and remove the key. All electrical circuits are cut off.

CAUTION:

Start the engine promptly after turning the ignition key to the "ON" position. The reason for this is that the headlight and taillight come on at the same time the ignition is turned on and will cause the battery to lose power.

WARNING:

Before turning the ignition switch to the (P) "PARK" or "LOCK" position, stop the motorcycle and place the motorcycle on either the side stand or the center stand.

INSTRUMENT PANEL

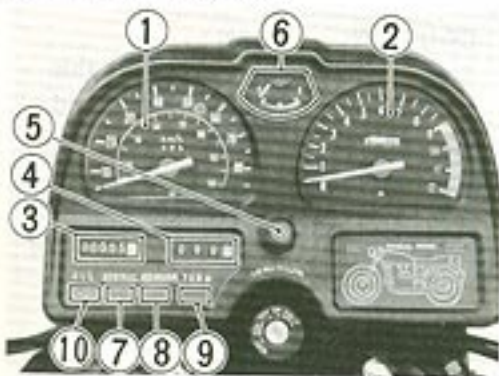

SPEEDOMETER ①

The speedometer indicates the road speed in miles per hour and kilometers per hour.

TACHOMETER ②

The tachometer indicates the engine speed in revolutions per minute (r/min.).

ODOMETER ③

The odometer registers the total distance that the motorcycle has been ridden.

TRIP METER ④

The trip meter is a resettable odometer located in the speedometer assembly. It can be used to indicate the distance traveled on short trips or between fuel stops. Pushing the knob ⑤ will return the meter to zero.

FUEL GAUGE ⑥

The fuel gauge indicates the amount of gasoline remaining in the fuel tank. The "E" mark indicates the tank is empty or nearly so. The "F" mark indicates the fuel tank is full.

NEUTRAL INDICATOR LIGHT ⑦

The green light will come on when the transmission is in neutral. The light will go out when you shift into any gear other than neutral.

HIGH BEAM INDICATOR LIGHT ⑧

The blue indicator light will be lit when the headlight high beam is turned on.

TURN SIGNAL INDICATOR LIGHT ⑨

When the turn signals are being operated either to the right or left side, the amber indicator light will flash.

OIL PRESSURE INDICATOR LIGHT ⑩

With the ignition switch in the "ON" position but the engine not started, the oil pressure indicator light should be lit. As soon as the engine is started, the light should go out.

CAUTION:

Whenever the oil pressure indicator lights up, indicating no oil pressure, stop the engine immediately. First check the oil level and determine if the proper amount of oil is in the engine. If the oil level is low, refill the engine to the correct level. If the light still does not go out, then have your authorized Suzuki dealer inspect your motorcycle to determine the difficulty. Do not operate the motorcycle when the light is lit as it may cause serious damage to the internal parts of the engine or transmission.

CHECK PANEL

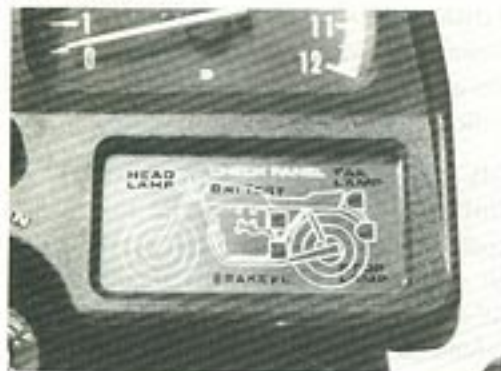

With the ignition switch in the "ON" position all indicator lights in the check panel turn on. As soon as the engine is started, the lights should go out. Whenever some of the indicator lights light up, something is wrong at the indicated position, so stop the engine immediately. Check the indicated position refer to the check and maintenance information mentioned in this owner's manual.

CAUTION:

Since the instrument panel of this motorcycle is used nylon based material, do not spill any oil or fluid (such as brake fluid) on it, otherwise the severe damage will be caused.

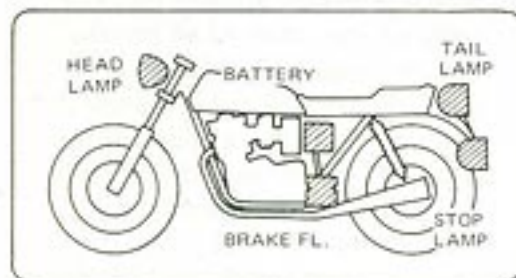

	Page
BATTERY	33
BRAKE FL	44
HEAD LAMP	58
TAIL LAMP	58
STOP LAMP	58

If the light still does not go out, then have your authorized Suzuki dealer inspect your motorcycle to determine the difficulty. Do not operate the motorcycle when the lights is lit as it may cause serious damage.

LEFT HANDLEBAR SWITCH

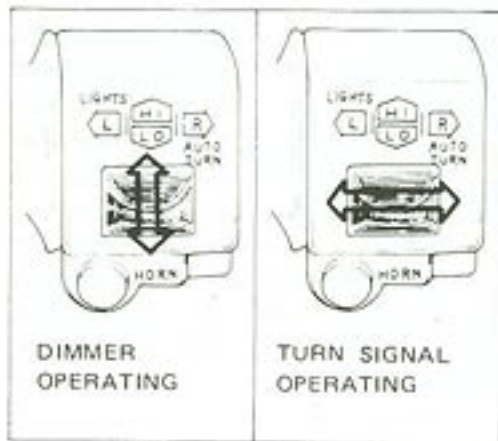
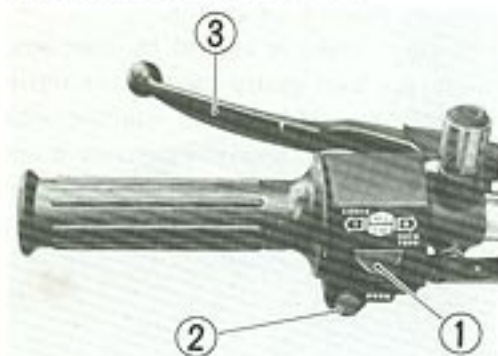

LIGHTS OPERATING SWITCH ① DIMMER OPERATING

When the lights operating switch is pushed up to the "HIGH" position, the high beam will be lit and the switch return to the center position. At the same time that the high beam is lit, the high beam indicator will also light in the center instrument panel. When the switch is pushed down to the "LO" position, the low beam will be lit and the switch return to the center position.

TURN SIGNAL OPERATING

Pushing the lights operating switch to the right or left lights up the right-hand or left-hand turn signal respectively, in that order. Returning the switch to center position puts out the signal, but you need not do so if a self-cancelling device is provided on the machine. After running for approx. 10 seconds total with a speed of 15 km/h (9.3 mph) or higher after switching on a turn signal, the cancelling device automatically turns off the light switch. The cancelling device works like a timer, counting time only when the

machine is running with the above-indicated speed. "10 seconds total" thus excludes any low-speed running duration.

WARNING:

Always use the turn signal when you intend to change lanes or make a turn.

HORN BUTTON ②

Press the button to operate the horn.

CLUTCH LEVER ③

The clutch lever is used to disengage the drive to the rear wheel when starting the engine or shifting the transmission gear. Squeezing the lever disengages the clutch.

RIGHT HANDLEBAR

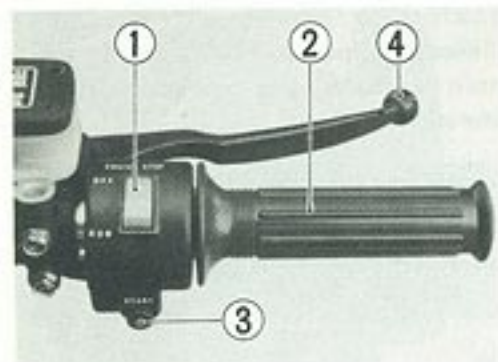

ENGINE KILL SWITCH ①

The engine "kill switch" is located on the top of the right handlebar grip switch housing. This is a "rocker" style switch which pivots in the center.

In the "RUN" position the ignition circuit is on and the engine will operate. The switch is intended primarily as a safety or emergency switch. When the switch is in the "OFF" position neither the starter motor nor the ignition circuit will be energized.

THROTTLE GRIP ②

Engine speed is controlled by the position of the throttle grip. Twist it toward you to increase engine speed. Turn it away from you to decrease the engine speed.

ELECTRIC STARTER BUTTON ③

Push the electric starter button in to engage the starter motor. The transmission should be in neutral for safety and the clutch disengaged during starting.

NOTE: The starter disconnect switch is equipped on this motorcycle. If the clutch lever is not disengaged, the starter motor will not rotate.

CAUTION:

Do not engage the starter motor for more than five (5) seconds at a time as it may overheat the wiring harness and starter motor. If the engine does not start after several attempts, check the fuel supply and ignition systems. (Refer to the troubleshooting section.)

FRONT BRAKE LEVER ④

The front brake is applied by squeezing the brake lever gently towards the throttle grip the GS1100E is equipped with a disc brake and excessive pressure is not required to slow the machine down properly. The brake light will be lit when the lever is squeezed inward.

FUEL TANK CAP



The fuel tank cap is a new low profile style which blends in smoothly with the lines of the fuel tank. To open the fuel tank cap insert the ignition key and turn the key clockwise. With the key still held in a clockwise position, lift up on the key and remove the filler cap. To install the fuel tank cap, simply line up the fuel tank cap guide pins and push down until the locking pins click into position as the arrow mark on the cap faces forward. The key must be in the cap lock or turned before installing cap. Turn the key counterclockwise and remove it.

WARNING:

When re-fueling, always shut the engine off and turn the ignition key to the "OFF" position. Never re-fuel around an open flame.

CARBURETOR CHOKE KNOB



The GS1100E carburetors are equipped with a "choke" system to provide easy starting. When starting a cold engine, pull the choke knob all the way up and engage the electric starter. After the engine starts, try to limit the engine RPM to approximately 2,000 RPM by varying the choke knob position. The choke system will operate only when the throttle is in the closed position as opening the throttle will bypass the choke system. When the engine is warm, the choke system does not need to be used for starting. Always be certain to push the choke knob back to its normal position after the engine reaches normal operating temperatures.

FUELCOCK

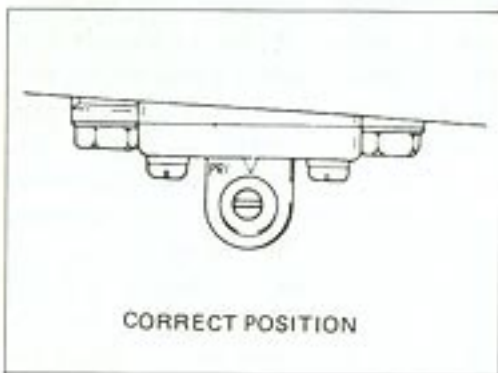

This motorcycle is equipped with an automatic type, diaphragm style fuelcock. No fuel will flow from the cock to the carburetor unless the engine is running or being started.

When the fuel gauge indicates the Red zone, this means the amount of gasoline remaining in the fuel tank is small.

NOTE: After the fuel gauge indicates the Red zone, it is advisable that the tank be refilled at the closest gas station.

CAUTION:

Always keep the plastic valve at the correct position illustrated above.

REAR BRAKE PEDAL

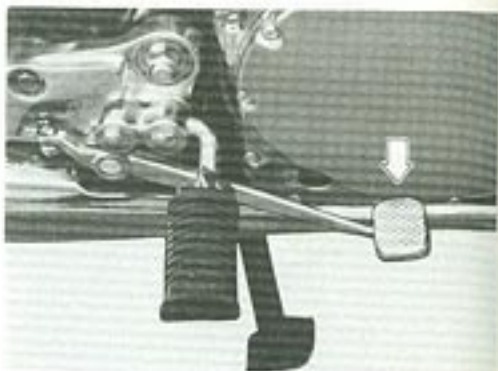

Depressing the rear brake pedal will apply the rear disc brake. The brake light will be lit when the rear brake is operated.

GEARSHIFT LEVER

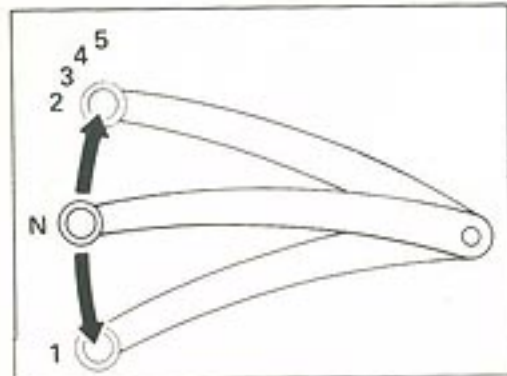

The GS1100E is equipped with a 5-speed constant mesh transmission which operates as shown in the figure. The shift lever is attached to a ratchet type mechanism in the transmission. Each time that a gear is selected, the gear shift lever will return to its normal position ready to select the next gear. Neutral is located between low and 2nd gear. Low gear is engaged by depressing the lever downward from the neutral position. Shifting into the higher gears is accomplished by lifting up on the shift lever once for each gear. It is not possible to up shift or down shift more than one gear at a time due the ratchet mechanism being used. When shifting from low to 2nd gear or 2nd gear to low, neutral will be automatically skipped. When neutral is desired, depress or lift the lever to a position halfway between low and 2nd gear.

CAUTION:

When the transmission is in neutral the green indicator light will be lit on the instrument panel. However, even though the light is lit, cautiously release the clutch lever slowly to determine whether the transmission is positively in neutral.

Reduce your road speed before downshifting. When down shifting, the engine RPM's should be increased before the clutch is engaged. This will prevent unnecessary wear on the drivetrain components and rear tire.

SEAT LOCK



The seat lock is located behind the seat. To remove the seat, insert the ignition key clockwise until the lock is released. Raise and slide back the seat by hand and unhook the seat hooks from the seat holding hooks. To lock the seat, hook the seat hooks into the seat holding hooks certainly, push down firmly, insert the key into the lock, push and turn the key counter clockwise and lock.

HELMET HOLDER



Use helmet holder in this manner. Insert the key, twist it counter-clockwise to open the latch, hook your helmet fastener ring to the latch and twist the key back to lock the holder.

WARNING:

Do not operate the motorcycle with a helmet fastened to the helmet holder. The helmet may be caught in the wheel causing an accident, or interfere with the safe operation of the motorcycle.

SUSPENSION

The front forks and rear shock absorbers are fully adjustable to compensate for rider, passenger, load, riding style, and road conditions. Please refer to the Inspection and Maintenance Section, page 48, for complete information and instructions.

STANDS

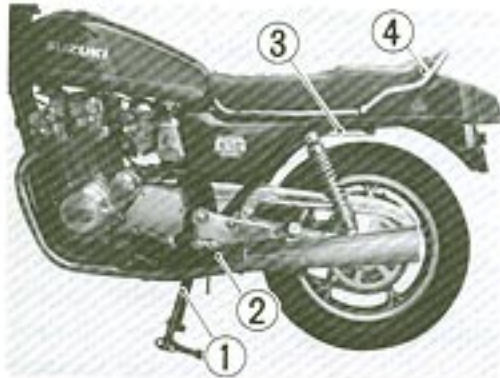

- ① Center stand
- ② Side stand
- ③ Lift bar
- ④ Hand rail

The motorcycle is equipped with both a center stand and a side stand. To place the motorcycle on the center stand, place your foot firmly on the stand extension and then rock the motorcycle to the rear and upward with the lift bar with your right hand, while steadying the handlebars with your left hand.

CAUTION:

The hand rail is designed to be used as a passenger hand hold only. Attempting to place or remove the motorcycle on or from the center stand using the passenger hand rail will damage it.

FUEL AND ENGINE OIL RECOMMENDATION

FUEL

Use only unleaded or low-lead type gasoline of at least 85 – 95 pump octane ($\frac{R+M}{2}$ method) or 89 octane or higher rated by the Research method. If engine pinging is experienced, substitute another brand as there are differences between brands.

NOTE: Unleaded and low-lead gasoline will extend spark plug life.

ENGINE OIL

Using a premium quality four stroke motor oil will increase the service life of your motorcycle. Use only oils which are rated SE under the API classification system. The viscosity rating should be SAE 10W-40. If the SAE 10W-40 motor oil is not available, select an alternative according to the chart below.

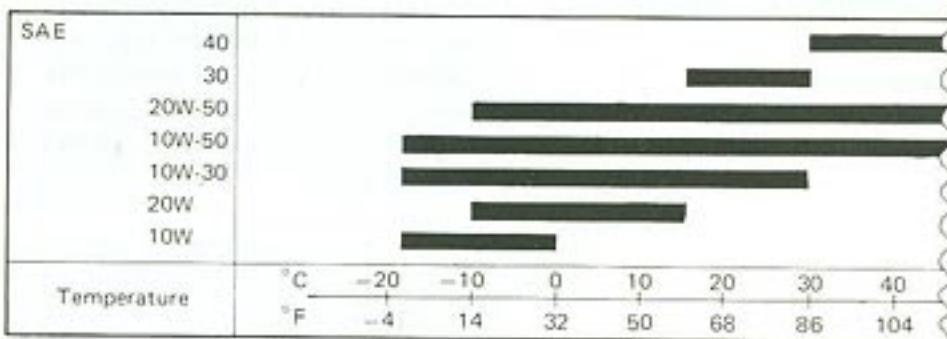

INSPECTION BEFORE RIDING

Before riding the motorcycle, be sure to check the following items. Never underestimate the importance of these checks. Perform all of them before riding the machine.

WHAT TO CHECK	CHECK FOR:
Steering	1) Smoothness 3) No play or looseness 2) No restriction of movement
Brakes	1) Proper pedal and lever play 3) No fluid leakage 2) No "sponginess"
Tires	1) Proper pressure 3) No cracks or cut spots 2) Adequate tread depth
Fuel	Enough fuel for the planned distance of operation
Lighting	Operation of all lights : HEADLIGHT, TAILLIGHT, BRAKE LIGHT, LICENSE PLATE LIGHT, INSTRUMENT LIGHTS, TURN SIGNALS
Indicator Lights	Oil Pressure, High beam, Neutral, Turn signal
Horn and "Kill Switch"	Proper function
Engine Oil	Proper level
Throttle	1) Proper play in the throttle cable 2) Smooth operation and positive return of the throttle grip to the closed position
Clutch	1) Proper play in the cable 2) Smooth and progressive action
Drive Chain	1) Proper tension or slack 2) Adequate lubrication
Air Forks	1) Smooth movement 2) Correct air pressure

STARTING THE ENGINE

Check that the engine kill switch is in the "RUN" position. Insert the ignition key into the ignition switch and turn it clockwise one notch to the "ON" position. The neutral indicator light will light if the transmission is in neutral.

CAUTION:

Always start the engine with the transmission in neutral, the clutch lever pulled in, and the rider in the normal riding position.

When the engine is cold:

Pull the carburetor choke knob to the engaged position all the way. Close the throttle completely and squeeze the clutch lever. Push the electric starter button and the engine will start. Immediately after the engine starts, keep the engine revolutions to a maximum of 2,000 rpm's by using the choke knob position for throttle control.

Push the choke knob all the way back to its normal disengaged position approximately 50 seconds after the engine starts.

In extremely cold weather it may be necessary to use the choke longer than 50 seconds.

When the engine is warm:

Open the throttle 1/8th to 1/4th turn and push the electric starter button. Operation of the carburetor choke system is usually not necessary when the engine is warm.

WARNING:

Do not run the engine indoors where there is little or no ventilation available. Carbon monoxide fumes are extremely poisonous. Never leave the motorcycle running while unattended, even for a moment.

STARTING OFF

Pull the clutch lever in and pause momentarily. Engage first gear by depressing the gear shift lever downward. Twist the throttle grip toward you and at the same time release the clutch lever gently and smoothly. As the clutch engages, the motorcycle will start moving forward.

To shift to the next higher gear, accelerate gently, then close the throttle and pull the clutch lever in simultaneously. Lift the gear shift lever upward to select the next gear and release the clutch lever and open the throttle again. Select the gears in this manner until top gear is reached.

USING THE TRANSMISSION

The transmission is provided to keep the engine operating smoothly in its normal operating rpm range. The gear ratios have been carefully chosen to meet the characteristics of the engine. The rider should always select the most suitable gear for the prevailing conditions. Never slip the clutch to control road speed, but rather downshift to allow the engine to run within its normal operational range. The table below shows the approximate speed range for each gear.

miles/h	0 ~ 12	12 ~ 19	19 ~ 25	25 ~ 31	Over 31
Gear position	1st	2nd	3rd	4th	5th
km/h	0 ~ 20	20 ~ 30	30 ~ 40	40 ~ 50	Over 50

RIDING ON HILLS

- When climbing steep hills, the motorcycle may begin to slow down and "lug" the engine excessively. At this point you should shift to a lower gear so that the engine will again be operating in its normal power range. Shift rapidly to prevent the motorcycle from losing momentum.
- When riding down a hill, the engine may be used for braking by shifting to a lower gear.
- Be careful, however, not to allow the engine to over rev.

WARNING:

- (1) If this is the first time that you have ridden a machine of this type, we suggest that you practice on a non-public road to become thoroughly familiar with the controls and operation of the motorcycle.
- (2) Before starting off, always return the side stand to its normal "up" position.
- (3) Slow down to a safe speed before negotiating a corner.
- (4) Don't down shift in the midst of cornering.
- (5) One-hand riding is extremely dangerous. Keep both hands firmly on the handlebars and both feet securely on the foot rests. Under no circumstances should both hands be removed from the handlebars.

USING THE BRAKES AND PARKING

- Twist the throttle grip away from yourself to close the throttle completely.
 - Apply the front and rear brakes evenly and at the same time.
 - Downshift through the gears as road speed decreases.
 - Select neutral with the clutch lever squeezed towards the grip (disengaged position) just before the motorcycle stops. Neutral position can be confirmed by observing the neutral indicator light.
- NOTE: Inexperienced riders tend to use the rear brake only. This can lead to premature brake wear and excessive stopping distances.*
- Apply the brakes lightly and with great care on a wet highway pavement or other slippery surfaces and at all corners. Any abrupt braking on slippery or irregular roads can be particularly dangerous.
 - If the motorcycle is to be parked on the side stand and on a slight slope, you may wish to leave the motorcycle in 1st gear to prevent it from rolling off of the side stand. Return to neutral before starting engine.
 - Turn the ignition switch to the "OFF" position to stop the engine.
 - Lock the steering for security.
 - Remove the ignition key from the switch.

WARNING:

Using only the front or rear brake is dangerous and can cause skidding and loss of control.

HIGH SPEED RIDING

High speed riding requires that certain adjustments be made to the suspension system of the motorcycle. Tire pressures should also be increased for high speed riding as described on page 47.

CAUTION:

Never allow the engine to exceed 9,000 rpm in any gear.

WARNING:

High speed cruising requires special care. Be sure that you review the pre-ride instruction chart and be sure that your machine is in top condition. Do not exceed the posted speed limits.

EMISSION INFORMATION

EPA

MAINTENANCE, REPLACEMENT, OR REPAIR OF THE EMISSION CONTROL DEVICES AND SYSTEMS MAY BE PERFORMED BY ANY MOTORCYCLE REPAIR ESTABLISHMENT OR INDIVIDUAL USING ANY MOTORCYCLE PART WHICH HAS BEEN CERTIFIED UNDER THE PROVISIONS IN THE CLEAN AIR ACT Sec. 207 (a) (2).

COMPLIANCE LABEL

The EPA compliance label is located on the rear fender. It provides much of the date required to perform an engine tune up on your GS1100E.

VEHICLE EMISSION CONTROL INFORMATION

SUZUKI MOTOR CO., LTD.  DISPLACEMENT : 1,074CC
ENGINE FAMILY IDENTIFICATION : GS110
ENGINE TUNE-UP SPECIFICATIONS: ALL ADJUSTMENTS ARE TO BE PERFORMED WITH TRANSMISSION IN NEUTRAL.
IGNITION TIMING : 12° BTDC AT IDLE SPEED.
IDLE SPEED : 1,050 RPM-ADJUSTMENT IS MADE BY TURNING THE THROTTLE STOP SCREW.
IDLE AIR/FUEL : NO ADJUSTMENT IS NECESSARY.
FUEL : LOW-LEAD OR UNLEADED GASOLINE
ENGINE OIL : SE OR SD IN API CLASSIFICATION, AND VISCOSITY RATING OF SAE 10W-40
REFER TO YOUR OWNER'S MANUAL FOR ADDITIONAL MAINTENANCE INSTRUCTIONS.
THIS VEHICLE CONFORMS TO U.S.E.P.A. REGULATION APPLICABLE TO 1980 MODEL YEAR NEW MOTORCYCLES.

PERIODIC MAINTENANCE SCHEDULE

MAINTENANCE SCHEDULE

The chart indicates the intervals between periodic services in miles (kilometers) and months. At the end of each interval, be sure to inspect, check, lubricate and service as instructed. If your motorcycle is used under high stress conditions such as continuous full throttle operation, or is operated in a dusty climate, certain services should be performed more often to insure reliability of the machine as explained in the maintenance section. Your Suzuki dealer can provide you with further guidelines. Steering components, suspension and wheel components are key items and require very special and careful

servicing. For maximum safety we suggest that you have these items inspected and serviced by your authorized Suzuki dealer.

WARNING:

Proper break-in maintenance (600 miles or 1,000 km) is a **MANDATORY** item for making certain that your machine is reliable and gives full performance at all times. Be sure that this periodic maintenance is performed thoroughly and in accordance with the instructions in this manual.

CAUTION:

Periodical inspections may reveal one or more parts that may need replacement. Whenever replacing parts on your motorcycle, it is recommended that you use Genuine Suzuki replacement parts or their equivalent. Whether you are an expert or de-it-yourself mechanic, Suzuki recommends that those items on the Inspection Chart marked with an asterisk (*), be performed by your authorized Suzuki dealer. You may perform the unmarked items easily by referring to the instructions in this section.

INTERVAL: THIS INTERVAL SHOULD BE JUDGED BY ODOMETER READING OR MONTHS, WHICHEVER COMES FIRST	mile	600	4,000	7,500	11,000	15,000
	km	1,000	6,000	12,000	18,000	24,000
	month	2	12	24	36	48
Battery		—	I	I	I	I
* Cylinder head nuts & exhaust pipe bolts		T	T	T	T	T
Air cleaner element		Clean every 2,000 miles (3,000 km), and replace every 7,500 miles (12,000 km).				

NOTE: T = Tighten, A = Adjust, I = Inspect, R = Replace, C = Clean.

INTERVAL: THIS INTERVAL SHOULD BE JUDGED BY ODOMETER READING OR MONTHS, WHICHEVER COMES FIRST	mile	600	4,000	7,500	11,000	15,000
	km	1,000	6,000	12,000	18,000	24,000
	month	2	12	24	36	48
* Valve clearance		I	I	I	I	I
Spark plug		—	C	R	C	R
* Fuel line		Replace every two years				
Engine oil and oil filter		R	R	R	R	R
Carburetor idle rpm		I	I	I	I	I
Clutch		I	I	I	I	I
Drive chain		I	I	I	I	I
		Clean and lubricate every 600 miles (1,000 km)				
* Brake hose		Replace every two years				
* Brake		I	I	I	I	I
Tire		I	I	I	I	I
* Steering		I	I	I	I	I
Front fork		—	—	I	—	I
		Check air pressure every 6 months				
* Chassis bolts and nuts		T	T	T	T	T

NOTE: T = Tighten, I = Inspect, R = Replace, C = Clean

TOOLS

To assist you in the performance of periodic maintenance, a tool kit is supplied and is located in the rear tail section behind the seat. The tool kit consists of the following items.

Ref. No.	Item
1.	Tool Bag
2.	8mm Open End Wrench
3.	10 x 12mm Open End Wrench
4.	14 x 17mm Open End Wrench
5.	Spark Plug Socket Wrench
6.	19mm Ring Wrench
7.	24mm Ring Wrench
8.	Ring Wrench Handle
9.	Socket Wrench Handle
10.	Combination Screwdriver
11.	Cross Head Screwdriver
12.	Screwdriver Handle
13.	Pliers
14.	Front Fork Air Pressure Gauge

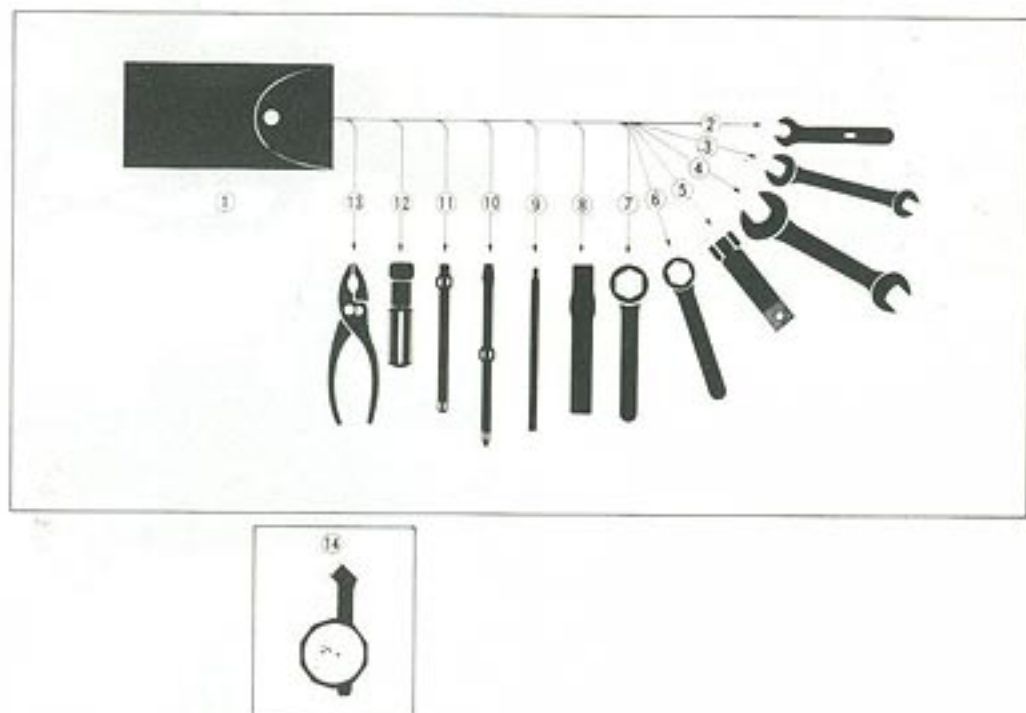

OILING CHART

Proper lubrication is important to smooth operation and long life of each working part of your motorcycle and also for safe riding. It is a good practice to oil the machine after a long rough ride and after getting it wet in the rain or after washing it. Major oiling points are indicated below.



Brake lever holder



Side stand pivot



Clutch lever holder



Rear brake rod link



Clutch cable

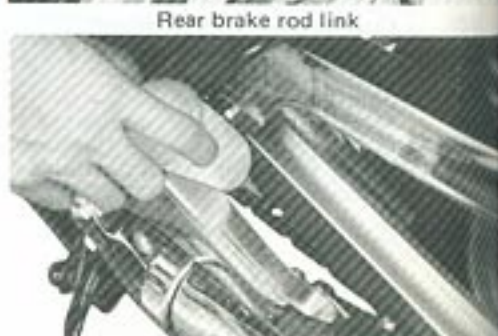

Drive chain

BATTERY



The battery solution level may be inspected by removing the right frame cover. The solution level must be kept between the upper and lower level lines at all times. If the solution level is below the lower limit line, add **ONLY** distilled water up to the upper limit line. **NEVER** use tap water.

WARNING:

Once the battery has been initially serviced, **NEVER** add diluted sulphuric acid.



CAUTION:

Be careful not to bend, obstruct, or change the routing of the air vent tube from the battery. Make certain that the vent tube is attached to the battery vent fitting and that the opposite end is always open.

NOTE: Every 4,000 miles (6,000 km) have your dealer check the specific gravity of the battery's cells with a battery hydrometer. This will determine the exact condition of each of the six (6) cells.

AIR CLEANER

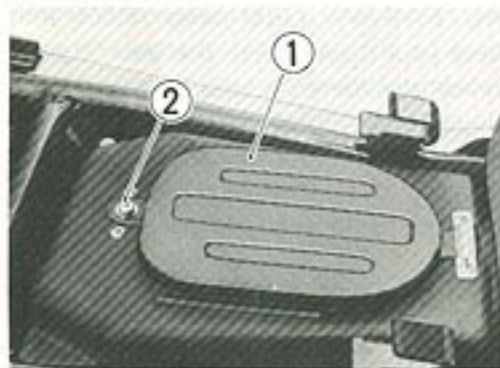

- ① Air cleaner case cover
- ② Screw

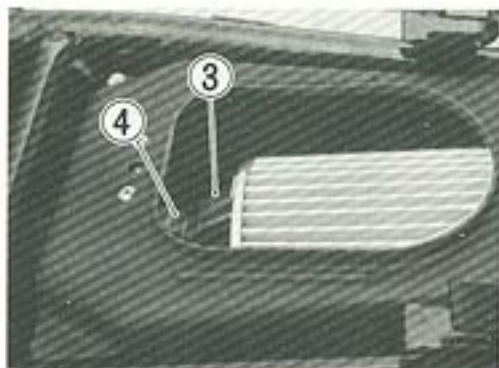

- ③ Spring bracket
- ④ Securing spring



The air cleaner element used in the GS 1100E is paper type. If the element has become clogged with dust, intake resistance will increase with a resultant decrease in power output and an increase in fuel consumption due to the richer mixture. Check and clean the air cleaner element every 2,000 miles (3,000 km) according to the following procedure.

- (1) Open the seat and remove the air cleaner case cover by unscrewing the one (1) Phillips head screw.
- (2) Remove the air cleaner element by pulling up on the spring retainer bracket.
- (3) Carefully use an air hose to blow the dust from the air cleaner element.

CAUTION:

Always apply air pressure to the inside of the air cleaner element only. If air pressure is used on the outside, dirt will be forced into the pores of the cleaner element restricting the air flow through the cleaner element.

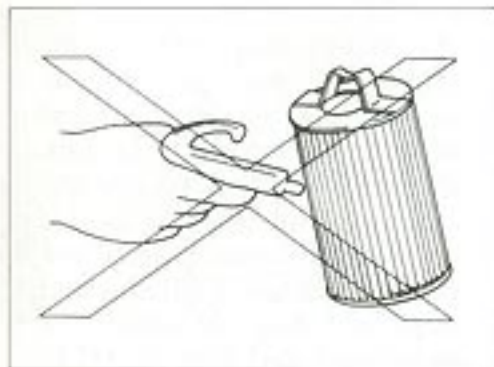

- (4) Reinstall the cleaned element or new air cleaner element in reverse order of removal, taking care to make sure that the spring bracket is properly engaged with the securing spring. Be absolutely sure that the element is securely in position and is sealing properly. Replace the air cleaner element with a new one every 7,500 miles (12,000 km).

CAUTION:

If driving under dusty conditions, the air cleaner element must be cleaned or replaced more frequently. **NEVER OPERATE THE ENGINE WITHOUT THE ELEMENT IN POSITION.** Operating the engine without the air cleaner element will increase engine wear. Always be sure that the air cleaner element is in excellent operational condition at all times. The life of the engine depends largely on this single component.

SPARK PLUGS

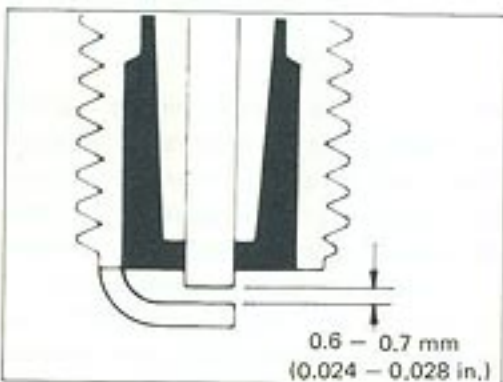
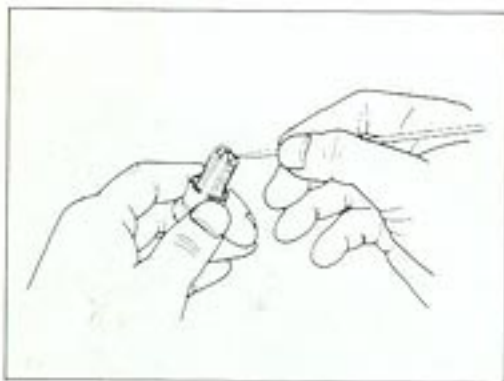

At 4,000 miles (6,000 km), remove the carbon deposits from the spark plug with a small wire brush or a spark plug cleaning machine. Readjust the spark plug gap

to 0.6 - 0.7 mm (0.024 - 0.028 in.) by using a spark plug gap thickness gauge. The spark plugs should be replaced every 7,500 miles (12,000 km).

Whenever removing the carbon deposits, be sure to observe the operational color of each spark plug's porcelain tip. This color tells you whether or not the standard spark plug is suitable for your type of usage. If the standard plug is wet appearing or very dark in color, the hotter spark plug may be more suitable. A normal operating spark plug should be very light gray in color. If the spark plug is very white or glazed appearing, then it has been operating much too hot. This spark plug should be replaced with the colder plug.

CAUTION:

The standard spark plug for the GS 1100E has been carefully selected to meet the vast majority of all operational ranges. If the spark plug color indicates that other than a standard spark plug be used, it is best to consult your Suzuki dealer before changing to a different heat range spark plug. The selection of an improper spark plug can lead to severe engine damage. Selecting another brand of spark plug other than NGK or Nippon Denso, may also lead to operational difficulties. You should consult your authorized Suzuki dealer before selecting an alternate brand.

NGK	NIPPON DENSO	REMARKS
D7EA	X22ES-U	If the standard plug is apt to get wet, replace with this plug.
D8EA	X24ES-U	Standard
D9EA	X27ES-U	If the standard plug is apt to overheat, replace with this plug.

ENGINE OIL AND OIL FILTER

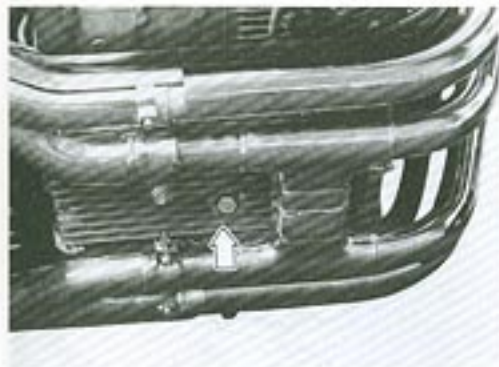

Drain plug



Oil filler cap



Engine oil inspection window

Superior engine life depends much on the selection of quality oil and the periodic changing of the oil. Daily oil level checks and periodic changes are two of the most important maintenances to be performed,

CAUTION:

Never operate the motorcycle if the engine oil level is below the "L" (low) line in the inspection window. Never fill the engine oil level above the "F" (full) line.

Change the engine oil and oil filter at the initial 600 miles (1,000 km) and also at the every 4,000 miles (6,000 km). The oil should always be changed when the engine is hot so that the oil will drain thoroughly from the engine. The procedure is as follows:

NOTE: About 3,200 ml (3.4 US qt.) of oil will be required when changing oil only.

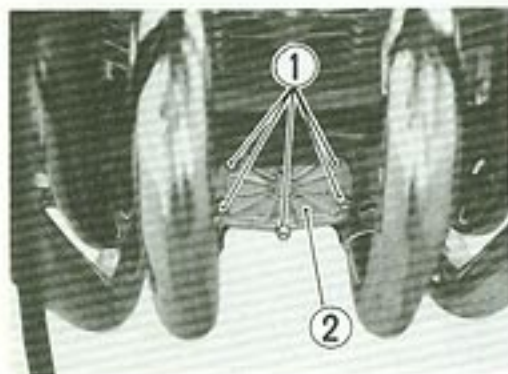

① Nut ② Filter cap

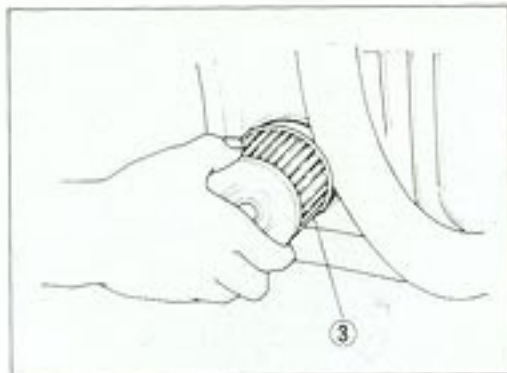

③ Oil filter

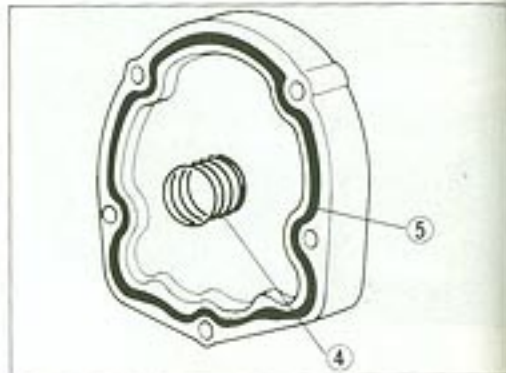

④ Spring ⑤ "O" ring

- (1) Place the motorcycle on the center stand.
- (2) Drain the engine oil by removing the drain plug from the bottom of the engine.
- (3) Remove the five (5) nuts holding the filter cap in place.
- (4) Remove the filter cap, pull out the element and replace with a new oil filter element. The rubber sealing ring is installed facing the engine.
- (5) Before replacing the oil filter cover, check to be sure that the filter spring and the cap "O" ring are installed correctly.
- (6) Replace the oil filter cover and tighten the nuts securely.
- (7) Replace the drain plug and tighten it securely. Add fresh oil through the filler hole approximately 3,600 ml (3.8 US qt.) will be required.
- (8) Start the engine and allow it to idle for several seconds.
- (9) Turn the engine off and wait approximately one minute, then recheck the oil level in the engine oil inspection window. The oil level should be at the "F" mark. If lower than the "F" mark, add oil until it reaches the mark.

CAUTION:

Be sure to always use the specified engine oil described on page 22.

CARBURETOR



Throttle stop screw

Undisturbed carburetion is the basis of the performance you ought to expect of your engine. The carburetor is factory-set for the best carburetion. Do not attempt to alter its setting. There are two items of adjustment, however, under your care: carburetor idle rpm and throttle cable play.

Inspect the carburetor idle rpm and throttle cable play at initial 600 miles (1,000 km) and every 4,000 miles (6,000 km).

CARBURETOR IDLE RPM ADJUSTMENT

- (1) Start up the engine and warm it up by running it at 2,000 rpm for 10 minutes in summer (where ambient temperature is 30°C (86°F) or thereabout) or for 20 minutes in winter (where ambient temperature is down to -5°C (23°F) or thereabout).
- (2) After engine warms up, turn the throttle stop screw located under the carburetor in or out so that engine may run at 1,050 ± 100 rpm.

CAUTION:

The carburetor idle rpm should be adjusted after the engine warms up.

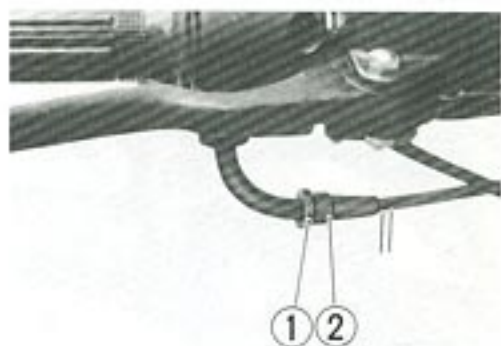

THROTTLE CABLE ADJUSTMENT

- 1) Loosen lock nut ①.
- 2) Adjust the cable slack by turning adjuster ② in or out to obtain the correct slack 1.0 – 1.5 mm (0.04 – 0.06 in).
- 3) After adjusting the slack, tighten the lock nut.

CLUTCH ADJUSTMENT

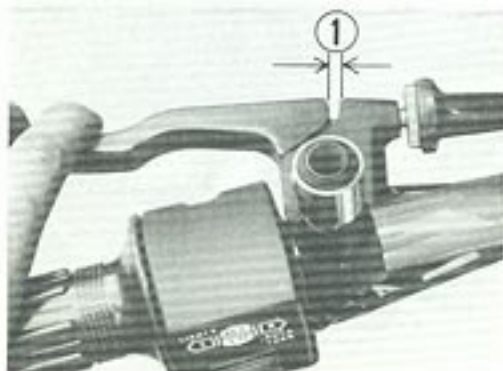

① Clutch cable play

At initial 600 miles (1,000 km) and every 4,000 miles (6,000 km), adjust the clutch by means of clutch cable adjuster.

The play ① of the clutch should be 2 – 3 mm (0.08 – 0.12 in) as measured at the clutch lever holder before the clutch begins to disengage. If you find the play of the clutch incorrect, adjust it in the following way.

- (1) Loosen the clutch cable adjuster lock nut ②.

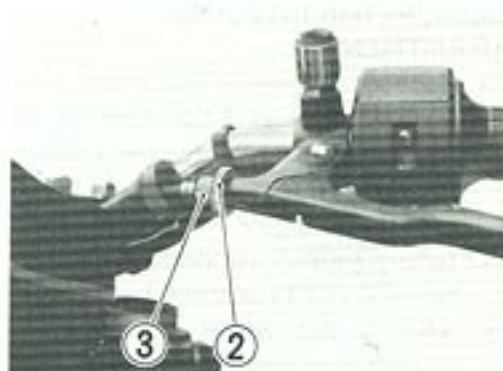

② Lock nut ③ Cable adjuster

- (2) Turn the clutch cable adjuster ③ to provide the specified play (2 – 3 mm).
- (3) Tighten the lock nut ②.

At the same intervals, lubricate the clutch cable with motor oil.

CAMSHAFT DRIVE CHAIN TENSIONER



The camshaft drive chain is kept in proper adjustment by an AUTOMATIC camshaft drive chain tensioner. This automatic tensioner never needs servicing by the customer and the camshaft drive chain itself need not be checked for stretch or wear.

CAUTION:

Never attempt to turn the tensioner wheel in either direction. Turning the wheel even slightly can jam the mechanism which will prevent it from adjusting the chain properly. An improperly adjusted chain can cause severe engine damage.

DRIVE CHAIN

The GS1100E is equipped with a special drive chain. It is an endless type that does not use a master link. We recommend that you take your GS1100E to your authorized Suzuki dealer to have the drive chain replaced when it becomes worn.

The drive chain is also constructed of special materials and has grease permanently sealed inside it by the use of special sealing "O" rings.

WARNING:

For maximum safety, the drive chain condition and adjustment should be checked prior to operating the motorcycle. Always follow the manufacturer's recommendations for replacement and for proper lubrication.

At the periodic inspections, performed at the initial 600 miles (1,000 km) and every 4,000 miles (6,000 km), the drive chain should be inspected for the following conditions.

- (1) Loose pins
- (2) Damaged rollers
- (3) Dry or rusted links
- (4) Kinked or binding links
- (5) Excessive wear
- (6) Improper chain adjustment

If the drive chain has any of these items wrong with it, then there is a strong possibility that the sprockets will have some damage to them also. Inspect the sprockets for the following:

- (1) Excessively worn teeth
- (2) Broken or damaged teeth
- (3) Loose sprocket mounting nut(s)

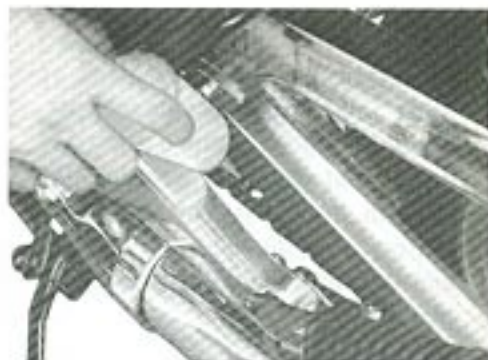

DRIVE CHAIN CLEANING AND OILING

Grease is permanently sealed inside the rollers of the GS1100E chain by the use of special "O" rings. At intervals of 600 miles (1,000 km) clean and oil the chain, as follows:

- (1) Cleaning the chain with kerosene is strongly recommended. If the chain tends to rust, the interval must be shortened. Kerosene is a petroleum product and will provide some lubrication as well as cleaning action.

CAUTION:

Do not use gasoline, trichlene or other commercial cleaning solvents. These fluids have a strong dissolving power that could damage the "O" rings in the chain. This will allow the grease to run out of the chain and the chain would have to be replaced.

- (2) Oiling the chain. After thoroughly washing the chain and allowing it to dry, oil the links with a heavy weight motor oil, 40 or 50 weight.

CAUTION:

Do not use any oil sold commercially as drive chain oil. These oils contain solvents and additives which could damage the "O" rings in the chain.

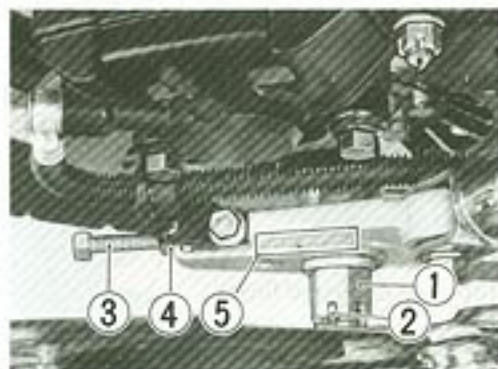
ADJUSTING DRIVE CHAIN

- ① Axle nut ④ Lock nut
 ② Cotter pin ⑤ Reference mark
 ③ Chain adjuster bolt

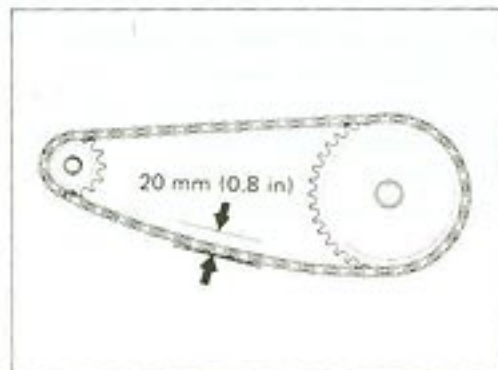

At the initial 600 miles (1,000 km) and a minimum of every 4,000 miles (6,000 km) adjust the drive chain to the proper specification. The chain may require more frequent adjustments depending upon your riding conditions.

WARNING:

These recommendations are the maximum intervals between the adjustment periods. The drive chain adjustment should be checked every time that the machine is operated. Excessive chain slack could cause the chain to come off the sprockets and result in an accident or serious engine damage. To adjust the drive chain, follow these directions.

- (1) Place the machine on the center stand.
- (2) Remove the cotter pin and loosen the axle nut.

- (3) Loosen the lock nuts.
- (4) Adjust the slack in the drive chain by turning the right and left chain adjuster bolts in after loosening the lock nut. At the same time that the chain is being adjusted, the rear sprocket must be kept in perfect alignment with the front sprocket. To assist you in performing this procedure, there are reference marks on the swing arm and each chain adjuster which are to be aligned with each other and to be used as a reference from one side to the other. After aligning and adjusting the slack in the drive chain to 20 mm (0.8 in), retighten the axle nut securely and replace the cotter pin with a new one. Tighten the chain adjuster lock nuts and perform a final inspection.

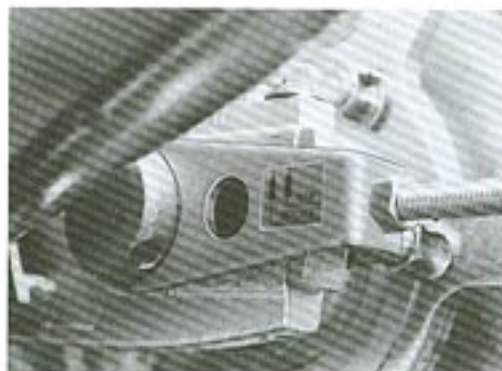

CAUTION:

Never allow the drive chain slack to exceed 50 mm (2 in). If the slack is allowed to be greater than this figure, the chain may come off the sprockets and cause severe engine damage or an accident. When the indicator mark on the chain adjuster aligns with the end of the swing arm, the drive chain should be replaced with a new one as it has become worn excessively. Refer to the drive chain information label on the chain guard.

CAUTION:

The drive chain for the GS1100E is made of a special material. The chain should be replaced with either a DAIDO DID630YL or a TAKASAGO RK630GSV. Use of another chain may lead to premature chain failure.

NOTE: The two sprockets should be inspected for wear when a new chain is installed and replaced if necessary.

BRAKES



The GS1100E utilizes front and rear disc brakes. Properly operating brake systems are vital to safe riding. Be sure to perform the brake inspection requirements as scheduled. The brakes should be inspected at the initial 600 miles (1,000 km) inspection and every 4,000 miles (6,000 km) thereafter, by your authorized Suzuki dealer.



BRAKE FLUID

WARNING:

Brake fluid may be harmful if swallowed or if it comes in contact with skin or eyes. Contact your physician immediately. If swallowed induce vomiting. If brake fluid gets into the eyes or incontact with the skin, it should be flushed thoroughly with plenty of water.

CAUTION:

The GS1100E uses a glycol-based brake fluid. Do not use or mix different types of brake fluid such as silicone-based or petroleum-based fluid, otherwise serious damage will result to the brake system. Never use any brake fluid that has been stored in a used or unsealed container. Never reuse brake fluid left over from the last servicing and stored for long periods as it absorbs moisture from the air. Use only DOT 3 or DOT 4 brake fluid. Do not spill any brake fluid on painted or plastic surfaces as it will damage the surface severely.

Be sure to check the brake fluid level in the front and rear reservoirs. If the level was found to be lower than the full mark, replenish with the proper brake fluid that meets Suzuki's requirements. As the brake pads wear, the fluid level will drop to compensate for the new position of the brake pads. Replenishing the brake fluid reservoir is considered normal periodic maintenance.



Inspect the front brake pads by noting whether or not the friction pads are worn down to the red limit line. If a pad is worn to the red limit line it must be replaced with a new one.



Inspect the rear brake pads for wear by noting whether or not the pad is worn down to the shoulder of each pad. If the shoulder is gone or nearly gone, the pad must be replaced with a new one. It is necessary to remove the pad inspection cap.

WARNING:

If the brake system or pads need to be repaired or serviced we strongly advise you to have your authorized Suzuki dealer perform service. He has the proper tools and proper training to perform the job in a safe and economical manner.

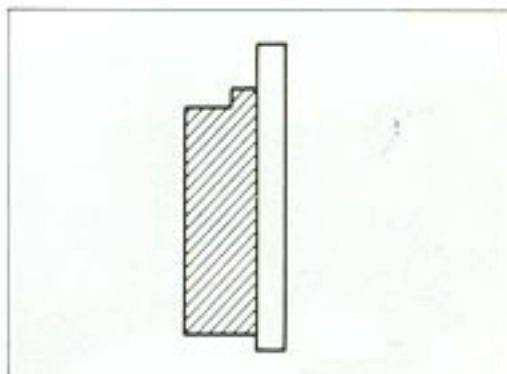

CAUTION:

Disc brake systems operate under extremely high pressures. For safety, the brake hose and brake fluid should be changed at intervals of no longer than two (2) years. Inspect your brake system for the following items daily.

- (1) Inspect the front and rear brake system for signs of fluid leakage.
- (2) Inspect the brake hose for leakage or a cracked appearance.
- (3) The brake lever should have the proper stroke and be firm at all times.
- (4) Check the wear of the disc brake pads.



FRONT BRAKE LIGHT SWITCH

The front brake light switch is located beneath the front brake lever. Loosen the switch fitting screws and adjust the actuating point by moving the switch body to the right or to the left so that the brake light will come on just before a pressure rise is felt at the lever.

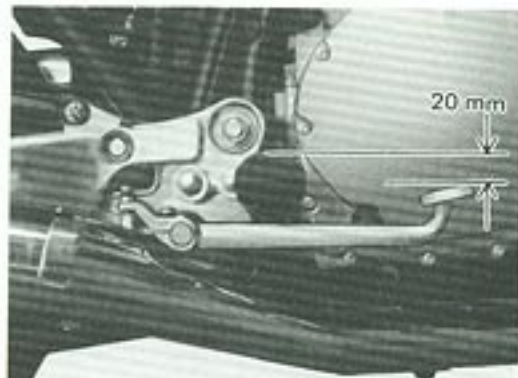

REAR BRAKE PEDAL ADJUSTMENT

The rear brake pedal must have a specified amount of clearance at all times or the disc brake pads will rub the disc causing damage to the pads and to the disc surface. Adjust the brake pedal in the following manner:

- (1) Loosen lock nut (A) and turn the stopper bolt (B) away from the stopper lug.
- (2) Loosen lock nut (C), and rotate the push rod (D) to locate the pedal 20 mm (0.8 in) below the top face of the foot rest.

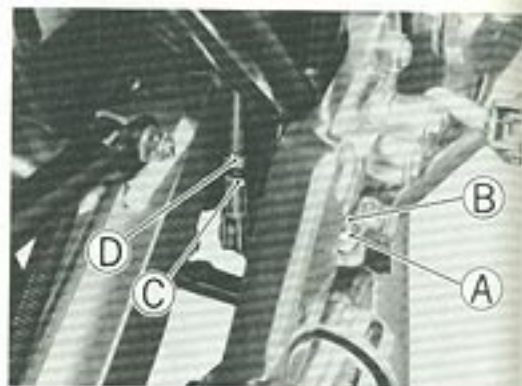

- (3) Retighten lock nut (C) to secure the push rod (D) in the proper position.
- (4) Adjust the clearance between the tip of the return stopper bolt (B) and the stopper lug so that the clearance is zero. Retighten the lock nut (A).



REAR BRAKE LIGHT SWITCH

The rear brake light switch is located under the right frame cover. To adjust the brake light switch: raise or lower the switch so that the brake light will come on just before a pressure rise is felt when the brake pedal is depressed.

TIRES

Check the tire inflation pressure and tire tread condition at the initial 600 miles (1,000 km) and each 4,000 miles (6,000 km) inspection. For maximum safety and good tire life, the tire pressures should be inspected more often.

TIRE PRESSURE

Insufficient air pressure in the tires not only hastens tire wear but also seriously affects the stability of the motorcycle. Under inflated tires make smooth cornering difficult and overinflated tires decrease the amount of tire in contact with the ground which can lead to skids and loss of control. Be sure that the tire pressure is within the specified limits at all times. Tire pressure should only be adjusted when the tires are cold.

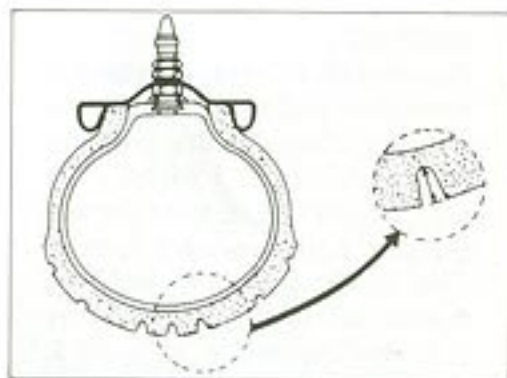

TIRE TREAD CONDITION

Operating the motorcycle with excessively worn tires will decrease riding stability and can lead to loss of control. It is recommended that the front tire be replaced when the remaining depth of tire tread becomes 1.6 mm (0.06 in) or less. The rear tire should be replaced when the tread becomes 2.0 mm (0.08 in) or less.

COLD INFLATION TIRE PRESSURE	FRONT				REAR			
	SOLO RIDING		DUAL RIDING		SOLO RIDING		DUAL RIDING	
	P.S.I.	KG/CM ²	P.S.I.	KG/CM ²	P.S.I.	KG/CM ²	P.S.I.	KG/CM ²
NORMAL RIDING	25	1.75	28	2.00	28	2.00	36	2.50
CONTINUOUS HIGH SPEED RIDING	28	2.00	32	2.25	32	2.25	40	2.80

* Tire pressure should be measured when tire is in cold condition.

WARNING:

The use of a tire type which is other than original equipment can lead to serious stability problems and possibly loss of control. Use only a 3.50V19-4PR front tire and a 4.50V17-4PR rear tire. V-rated tires are used on the GS1100E due to the high speed capability and handling ability of the GS 1100E. Suzuki strongly recommends that you use I.R.C., Bridgestone or Dunlop brand V-rated tires on your GS1100E.

WARNING:

Tire inflation pressures and the general tire condition are extremely important to the proper performance and safety of the vehicle. Check your tires frequently for both wear and inflation pressures.

NOTE: Refer to the tire information label on the chain guard.

FRONT SUSPENSION

The front suspension of this motorcycle is telescopic, pneumatic, 4-way adjustable oil dampened and 4-way adjustable coil spring type.

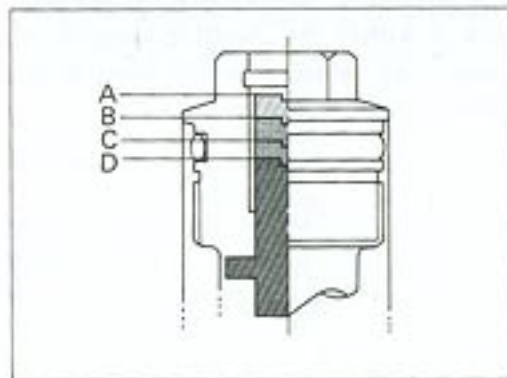
**FRONT SUSPENSION**

The standard front fork spring setting position is at the softest spring tension A. If this standard setting provides too soft for your cruising, the spring tension can be adjusted in the following way.

First remove the rubber cap, fit a plain-head screwdriver into the slot on the adjuster head and simultaneously turn it clockwise from A to B, to C and to D required, in that order. Thus the spring tension can be increased so that the front forks can be properly adjusted.

WARNING:

Making one front fork spring harder than the other will severely disturb the running stability.

Always make sure the adjusters are right in position, not in between the setting positions.

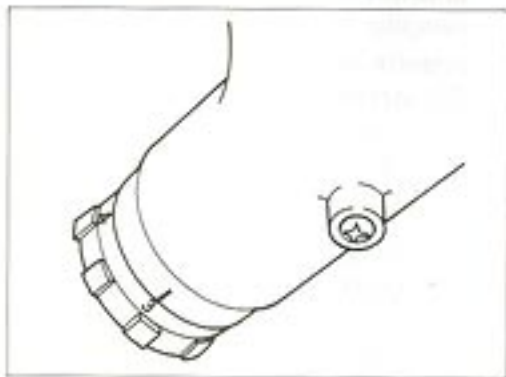

DAMPING ADJUSTER

To increase or decrease the damping force, turn this adjuster as shown in the photo. Damping adjustments, are indicated by the numbers 1 thru 4 engraved on the adjuster. As you turn the adjuster you will notice a click as you reach each number position. When changing the damping, always be sure that the adjuster stops with the number visible, that a click is noticed and adjuster feels as if it were sitting in a detent or a notch. Position 1 (softest) provides for the smallest amount of damping force, and position 4 (stiffest) for the largest amount. The GS1100E is delivered from the factory with both rear dampers adjusted to the number 2 position.

CAUTION:

Do not operate front damper units in any positions other than the click or detented positions. If position 2½, 3½, etc. is used, the damping force will automatically have the same damping force as number 4 (stiffest) position.

WARNING:

Making one front fork damping force harder than the other will severely disturb the running stability.

CHECKING THE AIR PRESSURE

This motorcycle is serviced at the factory with 0.5 kg/cm^2 (7.1 psi) of air pressure in the front forks.

To check the front fork air pressure, the motorcycle should be placed on its center stand and all weight removed from the front end by jacking up the front of the chassis or engine. Remove the air valve protection cap, loose the air lock bolts and use the air pressure gauge to check the front fork air pressure. To raise the pressure, use a hand pump to add air to each fork leg. To lower the pressure, bleed the air out from the valve.



- ① Air valve
- ② Air lock bolt



CAUTION:

Be sure to tight the air lock bolt firmly during operating your motorcycle.

CAUTION:

Do not attempt to alter the front fork air pressure setting by using a high pressure tire filler such as is available in gas stations. A hand type pump must be used so that no damage will occur to the fork assembly. Never use any air containing inflammable gases. Instead of ordinary air, nitrogen gas may be substituted if available. When pumping air in, never increase the pressure above 2.5 kg/cm^2 . This is the maximum permissible pressure to avoid fork oil seal and valve damage.

CAUTION:

Front fork adjustment, if necessary, must be made only with damper and spring adjuster. Never change the air pressure setting. Be sure to keep the front fork air pressure always at 0.5 kg/cm^2 .

NOTE: Fork air pressure, as with tire pressure, should be checked periodically (monthly) and especially after periods of non-use. When checking the pressure, be sure to apply the pressure gauge squarely to the air valve. After taking a reading, remove the gauge quickly. This must be done as some pressure is lost when removing the gauge. The loss ranges from 0.05 to 0.10 kg/cm². Take this loss of air pressure into consideration when adjusting for your final air pressure.

CAUTION:

Fork oil viscosity and level is critical to proper air fork operation. Draining or adding fork oil is best left to your Suzuki dealer as special tools and knowledge are necessary to perform this task.

REAR SUSPENSION

The rear shock absorber's spring preload and damping rate are adjustable. Spring preload can be altered to five different settings and the damping rate to four different settings.

These two variables can be adjusted to optimize the handling of the machine and the smoothness of the ride based on the speed, load, and road conditions.

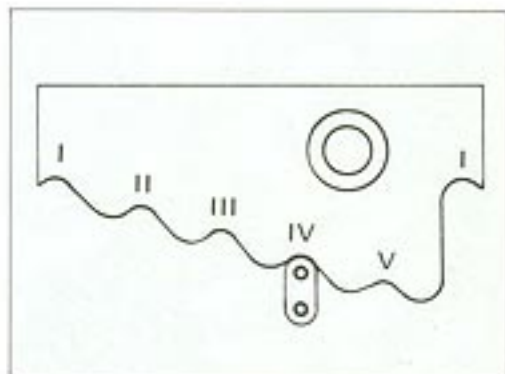

SPRING ADJUSTMENT

Turn the bottom spring seat, as shown in the photo, to the desired notch. This will change the preload on the spring and increase or decrease the stiffness of the ride. The GS1100E as delivered from the factory is adjusted so that both springs are on the number 1 notch for the softest possible ride.



DAMPING ADJUSTMENT

Roll the rubber dust cap up and away from the adjusting ring. To increase or decrease the damping force, turn this adjusting ring as shown in the photo. Damping adjustments, are indicated by the numbers 1 thru 4 engraved on the adjusting ring. As you turn the adjusting ring, you will notice a click as you reach each number position. When changing the damping, always be sure that the adjusting ring stops with the number visible, that a click is noticed and the ring feels as if it were sitting in a detent or a notch. Position 1 (softest) provides for the smallest amount of damping force, and position 4 (stiffest) for the largest amount. The GS1100E is delivered from the factory with both rear dampers adjusted to the number 1 position (softest position).

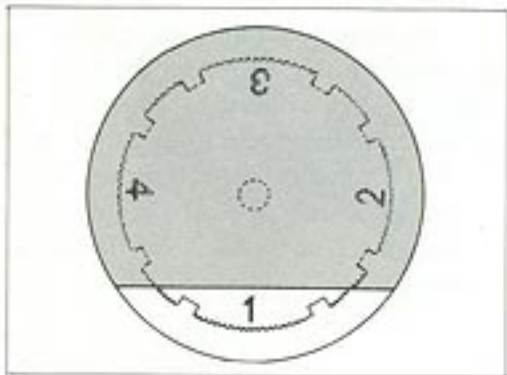

CAUTION:

Do not operate rear damper units in any positions other than the click or detented positions. If positions 2 $\frac{1}{2}$, 3 $\frac{1}{2}$, etc. are used, the damping force will automatically have the same damping force as number 4 (stiffest) position.

The rear suspension can be adjusted in accordance with your type of riding, road condition, speed, passenger weight, carrying load and etc.

A list of the recommended combinations is provided and should be followed.

WARNING:

- (1) Any combination other than those listed can be extremely dangerous and lead to loss of control of the motorcycle. For safe riding, be sure to follow the recommendations.
- (2) Be sure to adjust the springs and dampers of the two shock absorbers equally. Making one shock absorber harder than the other will severely disturb the running stability of the machine.

Spring Setting	Damper Setting
I	1 or 2
II	2 or 3
III	3 or 4
IV	3 or 4
V	4

FRONT WHEEL REMOVAL

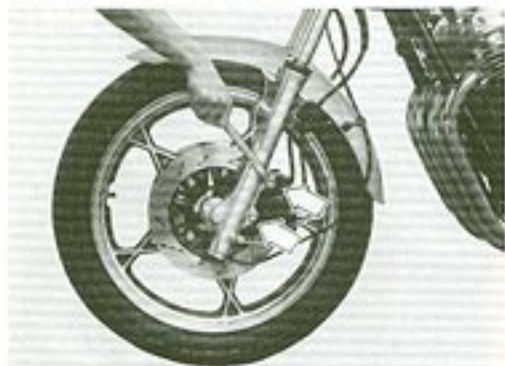

- (1) Place the motorcycle on the center stand.
- (2) Remove either one of two calipers, left or right, from the fork by unfastening its two mounting bolts.



- (3) Remove the cotter pin that locks the axle nut into position, then loosen the axle nut.
- (4) Draw out axle.

- (5) Lift the front end of the motorcycle up and place a jack or a block under the engine or chassis tubes.
- (6) Slide the front wheel forward. To re-install the wheel assembly reverse the sequence as described.



CAUTION:

Before tightening the axle in place, locate the speedometer drive gear box as photo above.

WARNING:

If the front wheel has to be removed, it is very important to have the loosened nuts and bolts torqued to the proper specifications. We suggest that you have this performed by a authorized Suzuki Dealer.

CAUTION:

Never squeeze the front brake lever with the front wheel removed. It is very difficult to force the pads back into the caliper assembly.

REAR WHEEL REMOVAL

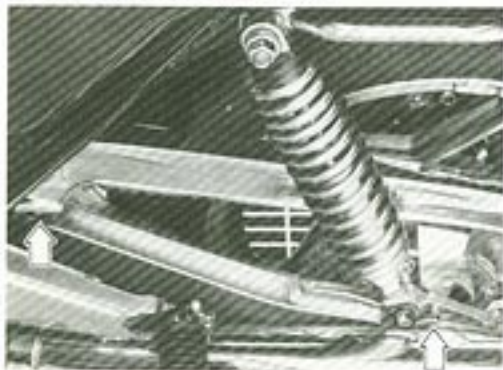

- (1) Place the machine on the center stand.
- (2) Remove the two chain guard bolts and then remove the chain guard cover.

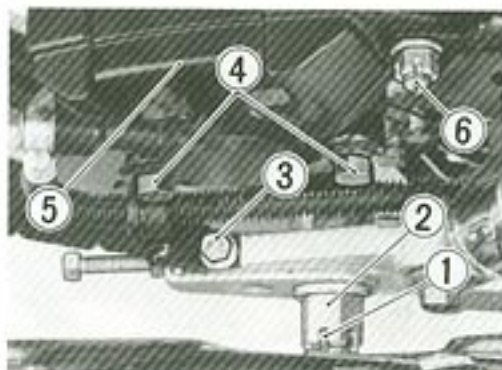

- ① Cotter pin ② Axle nut ③ Support bolt
④ Caliper mounting bolt ⑤ Caliper
⑥ Torque link bolt

- (3) Remove the cotter pin that locks the axle nut into position, then loosen the axle nut.
- (4) Remove the caliper mounting bolts, the torque link bolt cotter pin and the torque link bolt. Pivot the caliper out of the way.

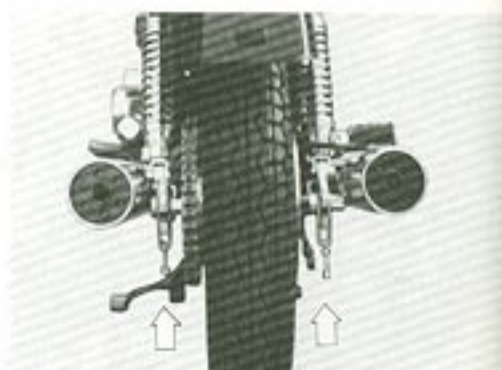

- (5) Pivot both chain adjusters downward, allowing the wheel to be pushed forward.



- (6) Remove the support bolts from each chain adjuster block and remove the adjuster block from swing arm.
- (7) With the wheel moved forward, remove the chain from the sprocket by slowly rotating the wheel, at the same time pulling the chain to the side.

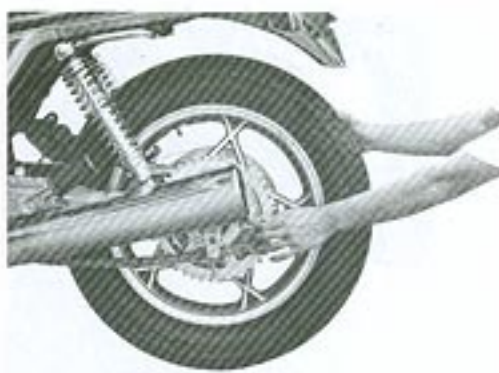

- (8) Pull the wheel assembly rearward and remove it from the swingarm. Slide the drive chain off of the hub when the wheel is far enough to the rear to provide the clearance required.
- (9) To replace the wheel reverse the complete sequence listed.

WARNING:

If you have found it necessary to remove the rear wheel, it is very important that the nuts and bolts be torqued to the proper specification. We strongly recommend that you have these bolts checked and retorqued by your authorized Suzuki Dealer.

CAUTION:

- (1) When reinstalling the rear wheel, be sure to follow the procedure outlined in the drive chain adjustment section. Double check all nuts, bolts and cotter pins after reinstalling the rear wheel.
- (2) While removing the caliper from the mounting bracket it is possible for the brake hose to touch the muffler. If the muffler is still hot, the hose could be damaged. Protect the hose with a cloth or wait until the muffler cools.
- (3) When reinstalling the rear caliper, be careful not to twist the brake hose or route it improperly.

LIGHT BULB REPLACEMENT

The wattage rating of each bulb is shown on the chart below. When replacing a burned out bulb, always use the exact same wattage rating. Using other than the specified rating can result in overloading the electrical system or premature failure of a bulb.

Headlight	12V 60/55W
Tail/Brake light	12V 8/23W (3/32 cp)
License plate light	12V 8W (3 cp)
Turn signal light	12V 23W (32 cp)

HEADLIGHT

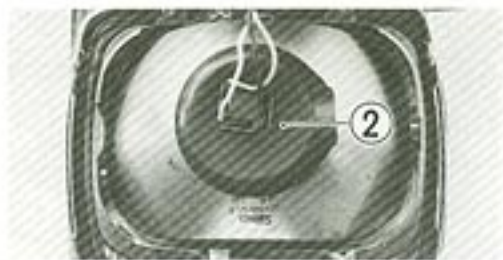

- (1) Remove three screws ① : take off the headlight assembly.
- (2) Roll up the rubber cap ② and unhook the bulb holder spring, and you can pull out the bulb ③ .

CAUTION:

In this model GS1100E, the halogen light is used for the headlight. When replacing the headlight bulb, be careful not to touch the lens of its bulb.

TAIL/BRAKE LIGHT



- ① Tail/Brake light
- ② License plate light

To replace the tail/brake light bulb or license plate light bulb, follow these directions:

- (1) Remove the four screws and take off the lens.
- (2) Push the bulb in, twisting it to the left until the engagement pins are disconnected and remove the bulb. To fit the replacement bulb into position, push the bulb in firmly and twist it to the right while pushing in.

CAUTION:

When replacing the lens, do not overtighten the four securing screws.

TURN SIGNAL LIGHT



- (1) Remove two screws and take off the lens.
- (2) Push the bulb, twisting it to the left, and pull it off.
- (3) To fit the replacement bulb, push it in and twist it to the right while pushing.

CAUTION:

After setting the lens, be careful not to overtighten the two securing screws lest the lens should break.

HEADLIGHT

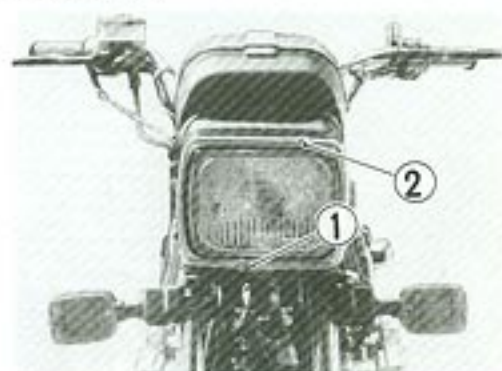

- ① Vertical line adjusting screw
- ② Horizontal line adjusting screw

The headlight beam can be adjusted both horizontally and vertically if necessary.

To adjust beam vertically:

Adjust the beam vertically by turning the vertical line adjusting screw.

To adjust beam horizontally:

Adjust the beam horizontally by turning the horizontal line adjusting screw.

FUSE BOX/OUTPUT TERMINAL



The fuse box/output terminal is located inside the left hand frame cover. There are five fuses. If there is a sudden halting of the engine while running or any electrical system failure then the fuses must be checked. In case one or more of the fuses blow there are two spare fuses, a 15A and a 10A fuses, located in the fuse box cover. For attaching electric accessories, the output terminal is provided under part of the fuse box.

When feeding current to an electric accessory from this output terminal, first remove fuse cover. Then, connect it to the terminal with extreme care not to

confuse its positive (+) and negative (-), following marks positive (+) and negative (-) on the terminal. After that, replace the fuse cover. The allowable current is 10A (12V).

CAUTION:

This output terminal is strictly provided for electric accessories, and so, any other usages are forbidden. In actual use for any electric accessory, please consult Suzuki dealer. It should be noted that a burnt out fuse should be replaced, removing fuse cover.

CAUTION:

Like other fuses, use none other than specified 10A fuse.

CAUTION:

Always be sure to replace the blown fuse with the correct amperage fuse. Never use a substitute, for example aluminum foil or wire, to replace a blown fuse. If the spare fuse installed blows out in a short period of time it means that you could have a major electrical problem. You should consult your Suzuki dealer immediately.

FUSE LIST

1. 15A MAIN fuse protects all electrical systems.
2. 10A HD. LAMP fuse protects headlight, taillight, license plate light, instrument light and high beam indicator light.
3. 10A SIGNAL fuse protects brake light, turn signal lights, turn signal indicator light and horn.
4. 10A IGNITION fuse protects the ignition system and electrical start system.
5. 10A OUTPUT TERMINAL fuse protects the electric accessories.

TROUBLESHOOTING

If the engine refuses to start, perform the following inspections to determine the cause.

- (1) Is there enough fuel in the fuel tank?
- (2) Is the fuel reaching the carburetors from the fuelcock?
- (3) Disconnect the fuel line from the carburetor, and crank the engine for a brief moment and see if fuel still flows.
- (4) If it has been determined that fuel is reaching the carburetor, the ignition system should be checked next.

WARNING:

Do not allow the fuel to spill, catch the fuel in a container.

- (1) Remove a spark plug and re-attach it to the spark plug lead.
- (2) While holding the spark plug firmly against the engine, push the starter button with the ignition switch in the "ON" position and the engine "kill" switch in the "RUN" position. If the ignition system is operating properly, a blue spark should jump across the spark plug gap. If there is no spark, consult your Suzuki Dealer for repairs.

WARNING:

Do not hold the spark plug close to the open spark plug hole in the cylinder head as gasoline vapor inside the cylinder could be ignited, creating a fire hazard.



ENGINE STALLING

- (1) Check the fuel supply in the fuel tank.
- (2) Check the ignition system for intermittent spark.
- (3) Check the engine idle speed.

It is best to consult your Suzuki dealer before attempting to troubleshoot any problem. If the machine is still within the warranty, then the Suzuki dealer should definitely be consulted before any repairs are attempted on the machine by yourself. Tampering with the machine while in warranty may affect warranty consideration.

STORAGE PROCEDURES

PROCEDURE FOR STORAGE

Materials Needed

1. Motor Oil.
2. Commercial Gasoline Stabilizer.
3. Commercial Rust Preventative Fogging Oil. (outboard motor type)
4. Commercial Aerosol Rust Preventative. (moisture displacing lubricant)
5. Commercial Vinyl and Rubber Preservative.
6. Hydrometer for Checking Battery Condition.
7. 1 Amp Battery Charger.

1. Place the motorcycle on its center stand.
2. Thoroughly clean the entire motorcycle. Run the bike until all traces of moisture are gone.
3. Pour the gasoline stabilizer into the fuel tank using the amount of stabilizer recommended by its manufacturer. Unstabilized fuel will form "gum" or "varnish" deposits that will plug the fuelcock and carburetor passageways.

NOTE: Steps 4a and 4b are for protecting the top end engine components from rust and corrosion. Step 4b is to be used only if fogging oil is not available. Do either 4a or 4b, but DO NOT do both.

- 4a. Remove the air cleaner element. While the engine is running at idle, spray the rust preventative fogging oil into the air cleaner box. Try to give each cylinder equal amounts of fogging oil. Do this until the engine stalls or emits smoke.
- 4b. Run the engine for a few minutes to get the stabilized fuel into the carburetors. Then, remove the spark plugs and pour 1 to 2 tablespoons of motor oil into each spark plug hole. Reinstall the spark plugs. DO NOT reinstall the spark plug caps at this time. Turn the engine over a few times with the electric starter. Now reinstall the spark plug caps.
5. Drain the old engine oil and remove the oil filter, but DO NOT replace it at this time. With fresh oil, refill the crankcase all the way up to the filler

cap hole. This step is necessary because the old oil contains acid, moisture and other contaminants that will damage the engine while it is stored.

6. Refill the fuel tank as completely as possible to eliminate any air space and to reduce the chances of the fuel becoming contaminated.
7. Remove the battery. Make sure to remove the negative terminal before the positive terminal. This will remove the battery from the circuit and will eliminate the chance of grounding the positive terminal with the screwdriver or wrench. Clean the outside of the battery with a mild baking soda and water solution and dry it carefully. Be sure not to get any solution inside the cells. Remove any corrosion from the terminals and from the wiring harness connections. Store the battery in a room that stays above freezing, off the floor, and preferably on a wooden shelf.
8. Spray all of the vinyl and rubber parts with the rubber preservative.

9. Spray the unpainted surfaces of the motorcycle with the rust preservative.
10. Deflate the tires to approximately 20 PSI and block up the front of the motorcycle so both front and rear tires are off of the ground. This will keep the tires from developing permanent "flat" spots.

During the storage period, be sure to do the following things:

Once A Week

Turn the engine over a few times by removing the spark plugs and putting the transmission in 5th gear and turning the rear wheel. This will keep the piston rings free and top end coated with oil. Reinstall the spark plugs and visually inspect your machine for any other things that would be detrimental to the condition of your motorcycle.

Once A Month

Recharge the battery with the one amp battery charger until it is fully charged. If the battery is not kept fully charged, it may become permanently damaged and will have to be replaced.

PROCEDURE FOR RETURNING TO SERVICE

1. Clean the entire motorcycle.

NOTE: Use of a commercial degreaser may stain the finish on the engine. Instead, use a mild detergent and water solution.

2. Drain the oil that was in the engine during the storage period. Install a new oil filter and fill the engine with oil as outlined in your owner's manual.
3. Reinstall the battery. Make sure that the vent hose is connected and routed properly. Install the positive terminal before the negative terminal.
4. Lubricate all places as instructed in the lubrication table in the owner's manual.
5. Inflate the tires to the correct pressure.
6. Before starting the engine, remove the four spark plugs and slowly turn the engine over by putting it in 5th gear and turning the rear wheel. Listen for any abnormal noises and

check for smooth movement. If you think a problem has occurred, contact your local authorized Suzuki dealer for assistance. If there are no problems, reinstall the spark plugs and return the transmission in neutral.

7. Do the "Inspections Before Riding" as listed in the owner's manual.

Often times it's easier to let these sort of services be done by your dealer. Most dealers in the areas where motorcycle storage is common are set up to properly prepare motorcycles for storage. Whether you do it yourself, or have your dealer do it, we sincerely hope you follow our suggestions. This is the only way that your GS can serve you in the manner it was designed. If your dealer does the service for you, you should be among the first to be back on the road when winter becomes spring.

CAUTION:

Clean the brake disc with alcohol only. This will ensure positive braking.

SPECIFICATIONS

DIMENSION AND DRY MASS

Overall length	2,245mm (88.4 in.)
Overall width	870mm (34.3 in.)
Overall height	1,190mm (46.9 in.)
Wheelbase	1,515mm (59.6 in.)
Ground clearance	155mm (6.1 in.)
Dry mass	243 kg (536 lbs)

ENGINE

Type	Four-strokecycle, air-cooled, DOHC
Number of cylinders	4
Bore	72.0mm (2.835 in.)
Stroke	66.0mm (2.598 in.)
Piston displacement	1,075cm ³ (65.6 cu. in.)
Compression ratio	9.5 : 1
Carburetor	MIKUNI BS34SS, four
Air cleaner	Paper element
Starter system	Electric
Lubrication system	Wet sump

**The engine displacement value marked on the engine cylinder may differ slightly from the displacement listed in the owner's manual because a different method of rounding off the displacement value was used.*

TRANSMISSION

Clutch	Wet multi-plate type
Transmission	5-speed constant mesh
Gearshift pattern	1-down 4-up
Primary reduction	1.775 (87/49)
Final reduction	2.800 (42/15)
Gear ratios, Low	2.500 (35/14)
2nd	1.777 (32/18)
3rd	1.380 (29/21)
4th	1.125 (27/24)
Top	0.961 (25/26)
Drive chain	DAIDO D.I.D. 630YL or TAKASAGO RK630GSV, 96 links

CHASSIS

Front suspension	Telescopic, pneumatic/coil spring, oil dampened damper 4-way/spring 4-way adjustable
Rear suspension	Swingingarm, oil dampened, damper 4-way/spring 5-way adjustable

Steering angle	40° (right & left)
Caster	62° 00'
Trail	103mm (4.06 in.)
Turning radius	2.8m (9.2 ft)
Front brake	Disc brake, double
Rear brake	Disc brake
Front tire size	3.50V19-4PR
Rear tire size	4.50V17-4PR

Fuse	10/10/10/10/15A
Headlight	12V 60/55W
Tail/Brake light	12V 8/23W (3/32 cp)
Turn signal light	12V 23W (32 cp)
License plate light	12V 8W (4 cp)
Speedometer light	12V 3.4W
Tachometer light	12V 3.4W
Neutral indicator light	12V 3.4W
High beam indicator light	12V 3.4W
Turn signal indicator light	12V 3.4W
Oil P. indicator light	12V 3.4W

ELECTRICAL

Ignition type	Transistorized
Ignition timing	12° B.T.D.C. below 1,500 rpm and 32° B.T.D.C. above 2,350 rpm
Spark plug	NGK D8EA or NIPPON DENSO X24ES-U
Battery	12V 50.4kC (14Ah)/10 Hours
Generator	Three-phase A.C. generator

CHECK PANEL

Head light	14V 1.4W
Taillight	14V 1.4W
Stop light	14V 1.4W
Battery	14V 1.4W
Brake FL	14V 1.4W

CAPACITIES

Fuel tank including reserve	19 L (5.0/4.2 US/Imp gal)
Engine oil when changing	3.2 L (3.4/2.8 US/Imp qt)
Front fork oil	238 ml (8.04/8.38 US/Imp oz)
	in each leg

WIRING DIAGRAM

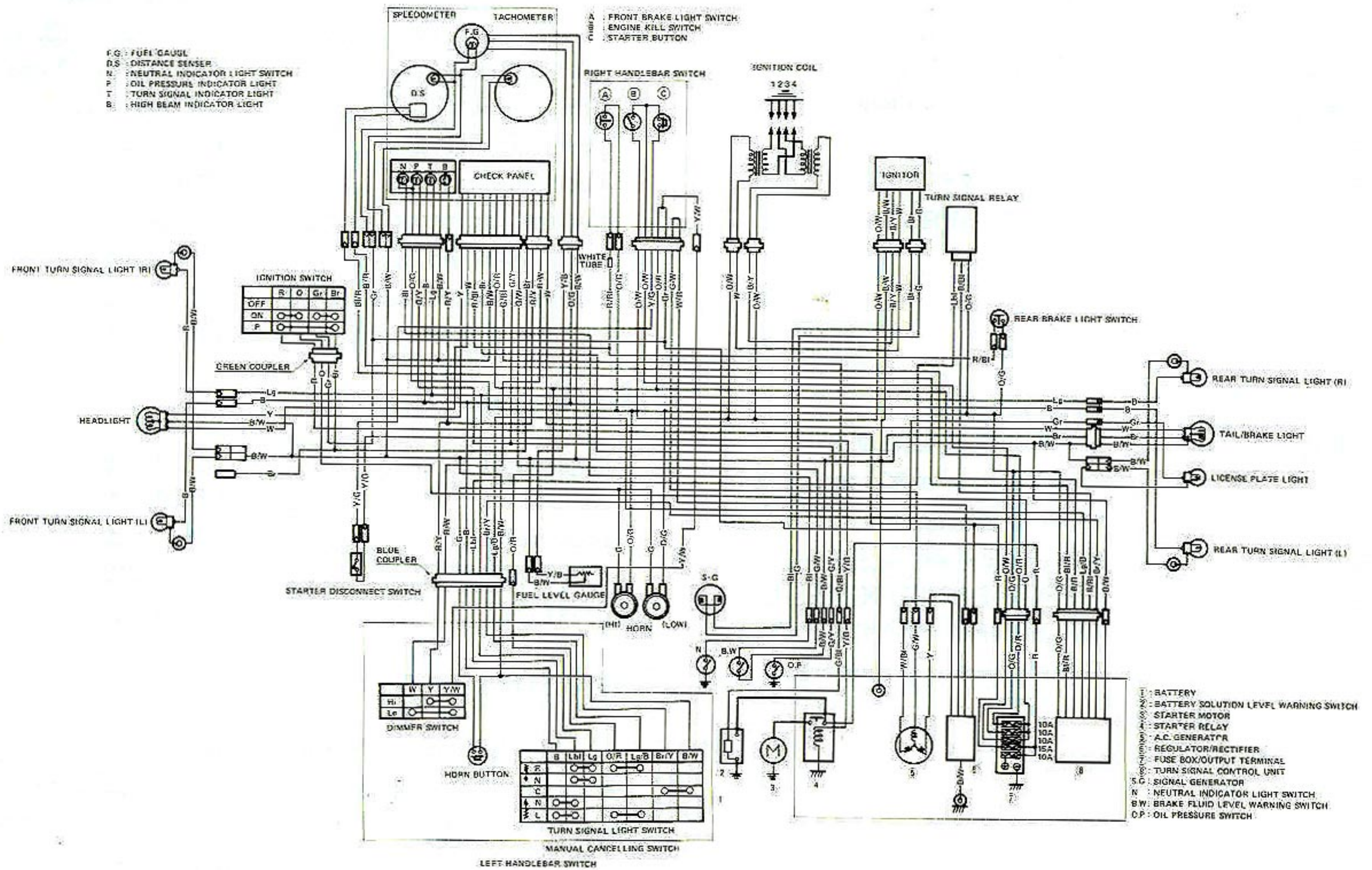

WIRE COLOR

B	Black	Bl/Y	Blue with Yellow tracer
Bl	Blue	Bl/W	Blue with White tracer
Br	Brown	Br/Y	Brown with Yellow tracer
G	Green	G/W	Green with White tracer
Gr	Gray	G/Y	Green with Yellow tracer
Lbl	Light blue	Lg/B	Light green with Black tracer
Lg	Light green	O/G	Orange with Green tracer
O	Orange	O/R	Orange with Red tracer
R	Red	O/W	Orange with White tracer
W	White	W/Bl	White with Blue tracer
Y	Yellow	W/G	White with Green tracer
B/Bl	Black with Blue tracer	W/R	White with Red tracer
B/R	Black with Red tracer	Y/Bl	Yellow with Black tracer
B/W	Black with White tracer	Y/G	Yellow with Green tracer
B/Y	Black with Yellow tracer	Y/W	Yellow with White tracer
Bl/R	Blue with Red tracer		

Prepared by

SUZUKI MOTOR CO., LTD.

Service Department
Overseas Operations Division

November, 1979

Part No. 99011-49220-03A

Printed in Japan

SUZUKI MOTOR CO., LTD. warrants to the ultimate purchaser and each subsequent purchaser that his vehicle (GS1100E) is designed, built, and equipped so as to conform at the time of sale with all U.S. emission standards applicable at the time of manufacture and that it is free from defects in materials and workmanship which would cause it not to meet these standards within the period of 5 years or 30,000 km (18,645 miles), whichever occurs first. Failures, other than those resulting from defects in material or workmanship, which arise solely as a result of owner abuse and/or lack of proper maintenance are not covered by the warranty.

SUZUKI MOTOR CO., LTD.

T

Part No. 99011-49220-03A
November, 1979 (T)
Printed in Japan